

MEDIUM VOLTAGE CABLES

ALUMINIUM CONDUCTOR • PRODUCT CATALOGUE



Tai Sin[®]

TABLE OF CONTENTS

INTRODUCTION OF TAI SIN ELECTRIC LIMITED	2
MV CABLES DESIGN & CONSTRUCTION	3
MV STANDARDS	4
TYPICAL CONSTRUCTION OF CABLE	
AL-XCTP AL/XLPE/CTS/PVC (Single Core/Three Core) 6.6kV to 33kV <i>XLPE insulated, Copper tape screen, PVC sheath, IEC 60502-2</i>	5
AL-XCTAP AL/XLPE/CTS/PVC/AWA/PVC (Single Core) 6.6kV to 33kV <i>XLPE insulated, Copper tape screen, PVC bedded, Aluminium wire armoured, PVC sheath, IEC 60502-2</i>	15
AL-XCTDAP AL/XLPE/CTS/PVC/DATA/PVC (Single Core) 6.6kV to 33kV <i>XLPE insulated, Copper tape screen, PVC bedded, Double aluminium tape armoured, PVC sheath, IEC 60502-2</i>	20
AL-XCTDP AL/XLPE/CTS/PVC/DSTA/PVC (Three Core) 6.6kV to 33kV <i>XLPE insulated, Copper tape screen, PVC bedded, Double steel tape armoured, PVC sheath, IEC 60502-2</i>	25
AL-XCTSP AL/XLPE/CTS/PVC/SWA/PVC (Three Core) 6.6kV to 33kV <i>XLPE insulated, Copper tape screen, PVC bedded, Steel wire armoured, PVC sheath, IEC 60502-2</i>	30
FRT-AL-XCTH AL/XLPE/CTS/LSZH (Single Core/Three Core) 6.6kV to 33kV <i>XLPE insulated, Copper tape screen, LSZH sheath, IEC 60502-2</i>	35
FRT-AL-XCTAH AL/XLPE/CTS/LSZH/AWA/LSZH (Single Core) 6.6kV to 33kV <i>XLPE insulated, Copper tape screen, LSZH bedded, Aluminium wire armoured, LSZH sheath, IEC 60502-2</i>	45
FRT-AL-XCTDAH AL/XLPE/CTS/LSZH/DATA/LSZH (Single Core) 6.6kV to 33kV <i>XLPE insulated, Copper tape screen, LSZH bedded, Double aluminium tape armoured, LSZH sheath, IEC 60502-2</i>	50
FRT-AL-XCTDH AL/XLPE/CTS/LSZH/DSTA/LSZH (Three Core) 6.6kV to 33kV <i>XLPE insulated, Copper tape screen, LSZH bedded, Double steel tape armoured, LSZH sheath, IEC 60502-2</i>	55
FRT-AL-XCTSH AL/XLPE/CTS/LSZH/SWA/LSZH (Three Core) 6.6kV to 33kV <i>XLPE insulated, Copper tape screen, LSZH bedded, Steel wire armoured, LSZH sheath, IEC 60502-2</i>	60
XCSP Pilot Cable Cu/XLPE/CTS/HDPE/SWA/PVC (Pairs) 5kV induced voltage <i>XLPE insulated, PVC bedded, Copper tape screen, PE inner sheathed, Steel wire armoured, PVC sheath</i>	65
APPENDIX	
CABLE TECHNICAL DATA	66
CABLE CURRENT CARRYING CAPACITY	67
TERMS & CONDITIONS OF SALES	75

INTRODUCTION

Tai Sin Electric Limited was incorporated in 1980 and has built a successful cable and wire business serving a diverse range of industries for both the private and public sectors in all categories of industrial, commercial, residential and offshore & marine projects. To cater for the robust growth in the regional market, Tai Sin operates three cable manufacturing plants, which are located in Singapore, Malaysia and Vietnam. All of which are fully equipped with the latest manufacturing facilities and technologies to meet increasing demands.

Over the years, Tai Sin has expanded and diversified steadily to become the Tai Sin Group of Companies, which is now public listed on the Main Board of Singapore Stock Exchange (SGX-ST).

We have grown steadily based on a sound business philosophy of providing quality products using leading edge technology, backed by unflinching excellence in customer service and faster turnaround time to maintain customer loyalty. These are also our beliefs and values that give us the strength and confidence to continue to grow, excel and succeed.

Tai Sin Electric Cables (Malaysia) Sdn. Bhd. is principally engaged in the manufacturing and trading of electric wires and cables. Since its incorporation in 1999, Tai Sin Electric Cables (Malaysia) Sdn. Bhd. has grown steadily over the years, building on the philosophy of providing quality products with excellent customer service and support. We have been catering to the cable needs and requirements of both large and small customers from wide range of industries. Our company supplies to electrical dealers, wholesalers and contractors for both private and public construction across infrastructure, industrial, commercial, data centre, and residential developments.

Our products, marketed under the brand name “Tai Sin”, are renowned for its quality and conform to recognized manufacturing standards including the Malaysian Standards (MS), Singapore Standards (SS), British Standards (BS), the International Electrotechnical Commission Standard (IEC) and Standar Nasional Indonesia (SNI).

Tai Sin firmly believes in continuously improving on our quality and our factory is capable of manufacturing both standard as well as customized electric wires and cables made to specific requirements. As testimony of our entrenched commitment to the pursuit of excellence and in our drive to continuously improve our quality, Tai Sin has obtained ISO 9001, ISO 14001 and ISO 45001 certifications. Our products are certified by SIRIM QAS International Sdn. Bhd., and are approved by Jabatan Kerja Raya (JKR) Malaysia, the Fire and Rescue Department of Malaysia (Bomba) and Suruhanjaya Tenaga (ST).

With the loyal support of our customer and suppliers, we are committed to further improve the quality of our products through research and development and serving our customers with faster turnaround time.

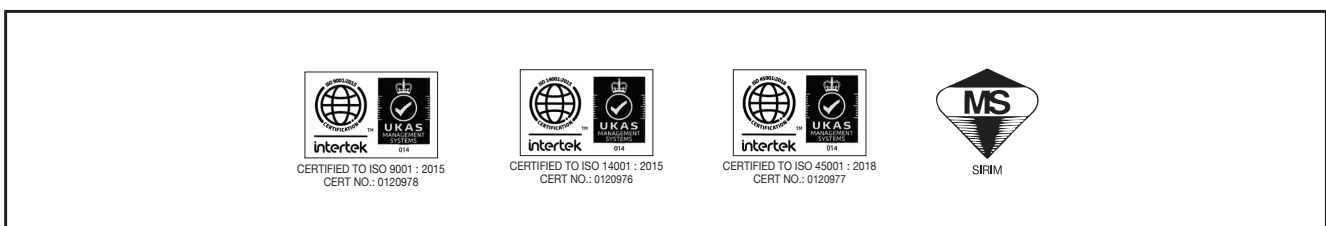

MV CABLES DESIGN & CONSTRUCTION

6.6 ~ 33 kV XLPE insulated PVC or LSZH sheathed cable construction



Single core and three core cables consist of the following components:

Conductor

Conductors are made of either copper or aluminium. Conductor design is usually circular stranded and compacted. Our conductor design is in compliance with the requirements of IEC 60228 and BS EN60228.

Conductor Screen

Conductor screen is non-metallic, extruded layer of semi conducting polyethylene to minimize electrical stresses due to the configuration of the stranded conductor.

Insulation

Cross-linked polyethylene (XLPE) insulation is as per IEC 60502-2. Triple extrusion process of inner semi-conductor screen, XLPE insulation and outer semi-conductor screen are applied. XLPE insulation is dry cured.

Insulation Screen

Insulation screen is non-metallic, extruded layer of semi conducting polyethylene to eliminate tangential and longitudinal stresses on the insulation surface.

Metallic Screen

The metallic screen is normally made of copper tape. Metallic screen can be of copper wires or combination of copper wires and tape, is available upon request.

Assembly

For three core cable - 3 insulated cores are laid together with interstices filled up by Polypropylene (PP) yarn fillers. A non-woven binder tape will be wrapped onto the practically round assembled core.

Inner Sheath

Cable inner sheath is made of extruded layer of PVC or low smoke halogen free (LSZH) material.

Armouring

Armouring is either aluminium material for single core or steel material for three core cables. Armouring can be either in wire or tape form.

Outer Sheath

Cable outer sheath is made of extruded layer of PVC or low smoke halogen free (LSZH) flame retardant polyolefin with anti-termite additives.

Testing of Medium Voltage Cable

All cables will go through the standard routine tests in accordance to IEC 60502-2 before delivery.

Routine Tests

Measurements of the Electrical Resistance of conductors
Partial Discharge Test
High Voltage Test

Sample Test

Conductor Examination
Check of Dimensions
Hot Set Test for XLPE Insulations

MV STANDARDS

Cable structure

Samples of 6.6~33 kV cross-linked polyethylene (XLPE) insulated polyvinyl-chloride (PVC) or low smoke zero halogen (LSZH) flame retardant sheathed cables

6.6~33 kV XLPE INSULATED POWER CABLE

Standards

General Types: IEC60502-2 equivalent to DIN VDE0276, BS7835 and BS6622

Flame retardant types: IEC60332 equivalent to DIN VDE0472-804 and BS4066

LSZH types: IEC60754, IEC61034 equivalent to DIN VDE0472-813, DIN VDE0472-816, BS6425, and BS7622

Conductor operating temperature : 90 °C
 Max. Short circuit temperature : 250 °C,
 Max. Duration : 5s.

Voltage adopted:		Unit: kV
Rated power frequency voltage between conductors (U)		Maximum voltage of equipment (Um)
6.6		7.2
11		12
15		17.5
22		24
33		36

Minimum installation bending radius:		
	PVC sheathed MV cables	LSZH sheathed MV cables
Single-core cable	12D	14D
Multi-core cable	10D	12D

Note: D=Cable outer diameter, mm

AL-XCTP AL/XLPE/CTS/PVC (Single Core)

XLPE Insulated, PVC Sheathed Cable 3.8/6.6KV (Max 7.2), IEC 60502-2

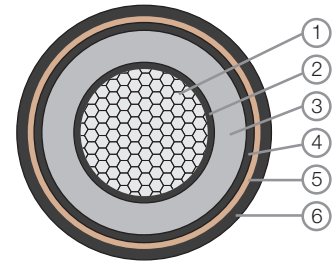
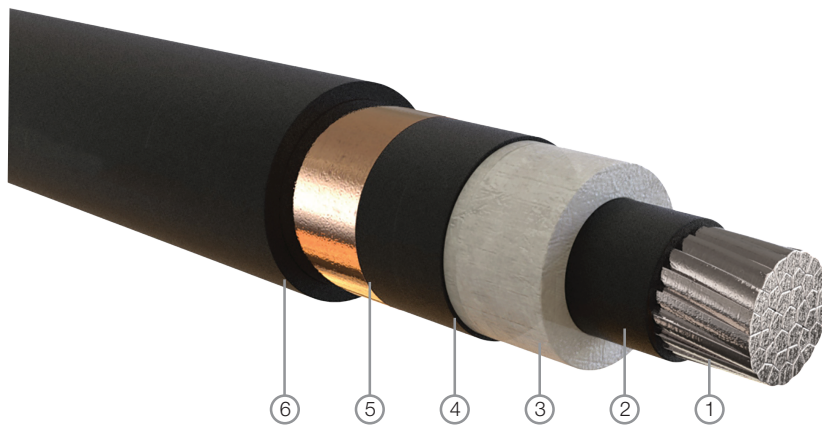

- Component**
1. Conductor
 2. Conductor screen
 3. Insulation
 4. Insulation screen
 5. Metallic screen (copper wire or copper tape)
 6. Outer sheath

CONSTRUCTION

Conductor:	Plain Annealed Aluminium, Class 2 Conductor
Conductor Screen:	Extruded Semi Conductive Compound
Insulation:	Cross-linked Polyethylene (XLPE) Compound
Insulation Screen:	Extruded semi conductive compound
Metallic Screen:	Copper Tape Screen
Outer Sheath:	Polyvinyl Chloride (PVC) Compound Type ST2
Outer Sheath Colour:	Black (other colours upon request)

ELECTRICAL CHARACTERISTICS

Operating Voltage:	3.8/6.6KV
Conductor Operating Temperature:	90°C
Final Short Circuit Temperature:	250°C
Test Voltage:	3.5U ₀

AL/XLPE/CTS/PVC (Single Core)

Nominal Area of Conductor (mm ²)	Nominal Diameter of Conductor (mm)	Approximate Weight of Conductor (kg/km)	Nominal Thickness of Insulation (mm)	Nominal Thickness of Outer Sheath (mm)	Approximate Overall Diameter (mm)	Approximate Cable Weight (kg/km)
70	9.7	182	2.5	1.8	23	640
95	11.3	251	2.5	1.8	24	770
120	12.8	317	2.5	1.8	26	900
150	14.2	390	2.5	1.8	27	960
185	15.9	493	2.5	1.8	29	1,090
240	18.3	645	2.6	1.9	32	1,340
300	20.3	803	2.8	2.0	35	1,560
400	23.2	1,027	3.0	2.1	38	2,040
500	26.2	1,305	3.2	2.2	41	2,400
630	30.0	1,720	3.2	2.3	46	2,900
800	34.0	2,200	3.2	2.4	50	3,500
1,000	38.2	2,750	3.2	2.6	55	4,300
1,200	43.0	3,290	3.2	2.8	60	5,000

Table 1

AL-XCTP AL/XLPE/CTS/PVC (Single Core)

XLPE Insulated, PVC Sheathed Cable 6.35/11KV (Max 12), IEC 60502-2

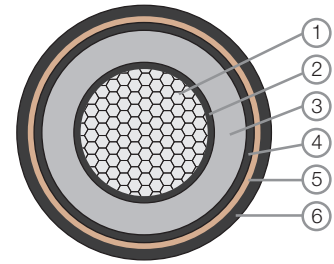
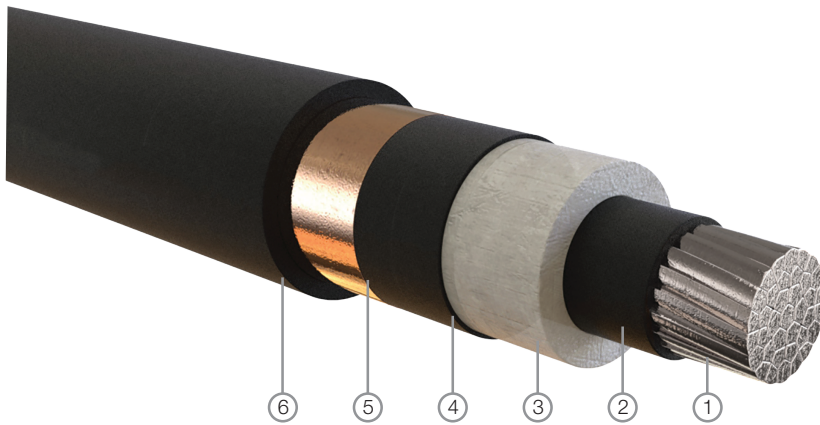

- Component**
1. Conductor
 2. Conductor screen
 3. Insulation
 4. Insulation screen
 5. Metallic screen (copper wire or copper tape)
 6. Outer sheath

CONSTRUCTION

Conductor:	Plain Annealed Aluminium, Class 2 Conductor
Conductor Screen:	Extruded Semi Conductive Compound
Insulation:	Cross-linked Polyethylene (XLPE) Compound
Insulation Screen:	Extruded semi conductive compound
Metallic Screen:	Copper Tape Screen
Outer Sheath:	Polyvinyl Chloride (PVC) Compound Type ST2
Outer Sheath Colour:	Black (other colours upon request)

ELECTRICAL CHARACTERISTICS

Operating Voltage:	6.35/11KV
Conductor Operating Temperature:	90°C
Final Short Circuit Temperature:	250°C
Test Voltage:	3.5U ₀

AL/XLPE/CTS/PVC (Single Core)

Nominal Area of Conductor (mm ²)	Nominal Diameter of Conductor (mm)	Approximate Weight of Conductor (kg/km)	Nominal Thickness of Insulation (mm)	Nominal Thickness of Outer Sheath (mm)	Approximate Overall Diameter (mm)	Approximate Cable Weight (kg/km)
70	9.7	182	3.4	1.8	25	680
95	11.3	251	3.4	1.8	27	800
120	12.8	317	3.4	1.8	28	930
150	14.2	390	3.4	1.8	30	1,010
185	15.9	493	3.4	1.9	32	1,190
240	18.3	645	3.4	2.0	34	1,440
300	20.3	803	3.4	2.0	36	1,660
400	23.2	1,027	3.4	2.1	39	2,100
500	26.2	1,305	3.4	2.2	44	2,500
630	30.0	1,720	3.4	2.3	47	3,100
800	34.0	2,200	3.4	2.5	51	3,600
1,000	38.2	2,750	3.4	2.6	55	4,400
1,200	43.0	3,290	3.4	2.8	61	5,100

Table 2

AL-XCTP AL/XLPE/CTS/PVC (Single Core)

XLPE Insulated, PVC Sheathed Cable 8.7/15KV (Max 17.5), IEC 60502-2

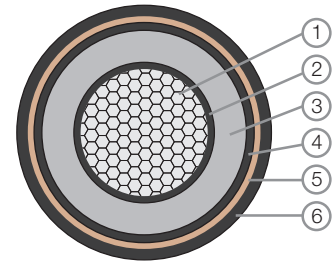
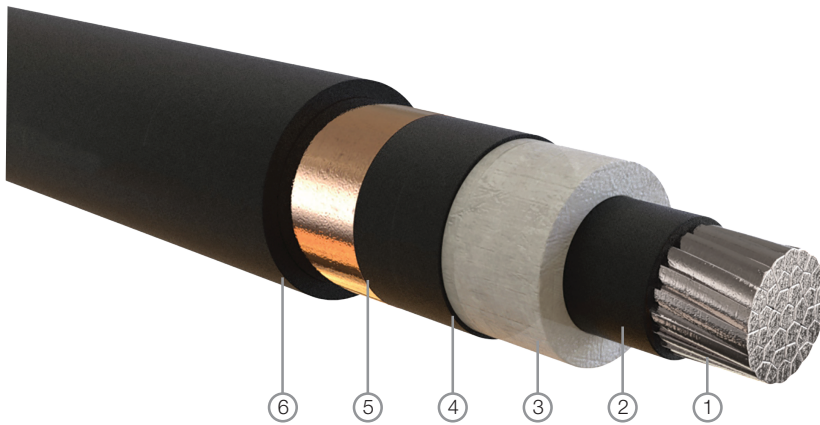

- Component**
1. Conductor
 2. Conductor screen
 3. Insulation
 4. Insulation screen
 5. Metallic screen (copper wire or copper tape)
 6. Outer sheath

CONSTRUCTION

Conductor:	Plain Annealed Aluminium, Class 2 Conductor
Conductor Screen:	Extruded Semi Conductive Compound
Insulation:	Cross-linked Polyethylene (XLPE) Compound
Insulation Screen:	Extruded semi conductive compound
Metallic Screen:	Copper Tape Screen
Outer Sheath:	Polyvinyl Chloride (PVC) Compound Type ST2
Outer Sheath Colour:	Black (other colours upon request)

ELECTRICAL CHARACTERISTICS

Operating Voltage:	8.7/15KV
Conductor Operating Temperature:	90°C
Final Short Circuit Temperature:	250°C
Test Voltage:	3.5U ₀

AL/XLPE/CTS/PVC (Single Core)

Nominal Area of Conductor (mm ²)	Nominal Diameter of Conductor (mm)	Approximate Weight of Conductor (kg/km)	Nominal Thickness of Insulation (mm)	Nominal Thickness of Outer Sheath (mm)	Approximate Overall Diameter (mm)	Approximate Cable Weight (kg/km)
70	9.7	182	4.5	1.8	27	790
95	11.3	251	4.5	1.8	29	920
120	12.8	317	4.5	1.9	31	1,030
150	14.2	390	4.5	1.9	32	1,200
185	15.9	493	4.5	2.0	34	1,350
240	18.3	645	4.5	2.0	36	1,550
300	20.3	803	4.5	2.1	39	1,800
400	23.2	1,027	4.5	2.2	42	2,200
500	26.2	1,305	4.5	2.3	45	2,600
630	30.0	1,720	4.5	2.4	49	3,300
800	34.0	2,200	4.5	2.5	53	3,800
1,000	38.2	2,750	4.5	2.7	58	4,600
1,200	43.0	3,290	4.5	2.9	64	5,400

Table 3

AL-XCTP AL/XLPE/CTS/PVC (Single Core)

XLPE Insulated, PVC Sheathed Cable 12.7/22KV (Max 36), IEC 60502-2

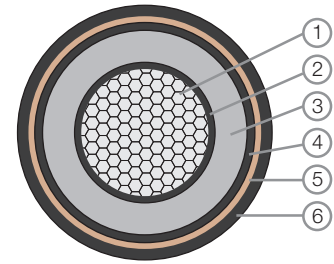
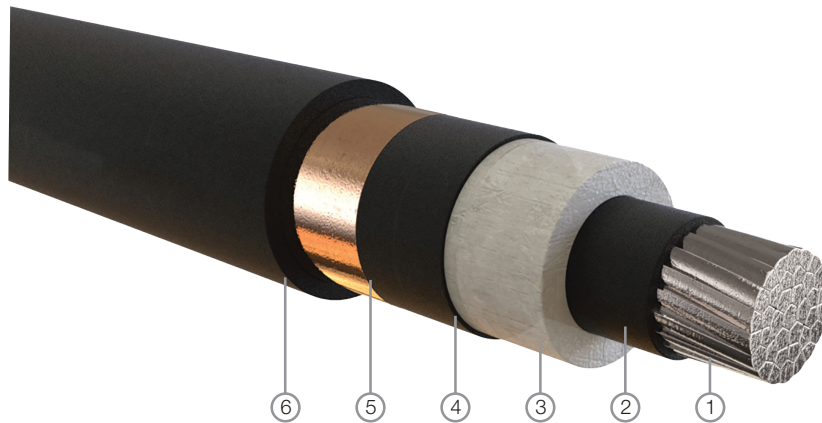

- 1. Conductor
- 2. Conductor screen
- 3. Insulation
- 4. Insulation screen
- 5. Metallic screen (copper wire or copper tape)
- 6. Outer sheath

CONSTRUCTION

Conductor:	Plain Annealed Aluminium, Class 2 Conductor
Conductor Screen:	Extruded Semi Conductive Compound
Insulation:	Cross-linked Polyethylene (XLPE) Compound
Insulation Screen:	Extruded semi conductive compound
Metallic Screen:	Copper Tape Screen
Outer Sheath:	Polyvinyl Chloride (PVC) Compound Type ST2
Outer Sheath Colour:	Black (other colours upon request)

ELECTRICAL CHARACTERISTICS

Operating Voltage:	12.7/22KV
Conductor Operating Temperature:	90°C
Final Short Circuit Temperature:	250°C
Test Voltage:	3.5U ₀

AL/XLPE/CTS/PVC (Single Core)

Nominal Area of Conductor (mm ²)	Nominal Diameter of Conductor (mm)	Approximate Weight of Conductor (kg/km)	Nominal Thickness of Insulation (mm)	Nominal Thickness of Outer Sheath (mm)	Approximate Overall Diameter (mm)	Approximate Cable Weight (kg/km)
70	9.7	182	5.5	1.8	29	890
95	11.3	251	5.5	1.9	31	1,030
120	12.8	317	5.5	1.9	33	1,180
150	14.2	390	5.5	2.0	34	1,400
185	15.9	493	5.5	2.0	35	1,590
240	18.3	645	5.5	2.1	38	1,800
300	20.3	803	5.5	2.2	41	2,000
400	23.2	1,027	5.5	2.3	44	2,500
500	26.2	1,305	5.5	2.4	47	2,900
630	30.0	1,720	5.5	2.5	51	3,500
800	34.0	2,200	5.5	2.6	56	4,050
1,000	38.2	2,750	5.5	2.7	60	4,900
1,200	43.0	3,290	5.5	2.9	66	5,530

Table 4

AL-XCTP AL/XLPE/CTS/PVC (Single Core)

XLPE Insulated, PVC Sheathed Cable 19/33KV (Max 36), IEC 60502-2

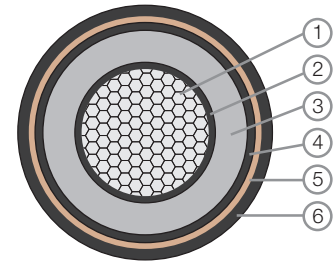
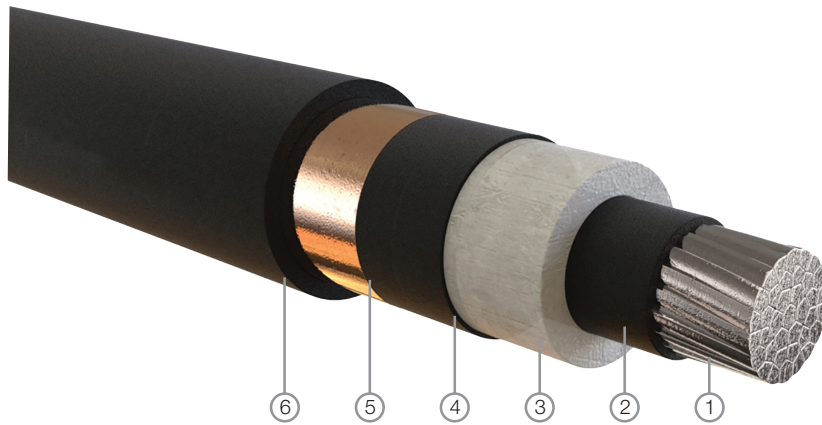

- Component**
1. Conductor
 2. Conductor screen
 3. Insulation
 4. Insulation screen
 5. Metallic screen (copper wire or copper tape)
 6. Outer sheath

CONSTRUCTION

Conductor:	Plain Annealed Aluminium, Class 2 Conductor
Conductor Screen:	Extruded Semi Conductive Compound
Insulation:	Cross-linked Polyethylene (XLPE) Compound
Insulation Screen:	Extruded semi conductive compound
Metallic Screen:	Copper Tape Screen
Outer Sheath:	Polyvinyl Chloride (PVC) Compound Type ST2
Outer Sheath Colour:	Black (other colours upon request)

ELECTRICAL CHARACTERISTICS

Operating Voltage:	19/33KV
Conductor Operating Temperature:	90°C
Final Short Circuit Temperature:	250°C
Test Voltage:	3.5U ₀

AL/XLPE/CTS/PVC (Single Core)

Nominal Area of Conductor (mm ²)	Nominal Diameter of Conductor (mm)	Approximate Weight of Conductor (kg/km)	Nominal Thickness of Insulation (mm)	Nominal Thickness of Outer Sheath (mm)	Approximate Overall Diameter (mm)	Approximate Cable Weight (kg/km)
70	9.7	182	8.0	2.0	35	1,200
95	11.3	251	8.0	2.1	37	1,400
120	12.8	317	8.0	2.1	38	1,500
150	14.2	390	8.0	2.1	40	1,600
185	15.9	493	8.0	2.2	42	1,800
240	18.3	645	8.0	2.3	44	2,100
300	20.3	803	8.0	2.3	46	2,500
400	23.2	1,027	8.0	2.5	50	2,800
500	26.2	1,305	8.0	2.5	53	3,500
630	30.0	1,720	8.0	2.7	57	4,000
800	34.0	2,200	8.0	2.8	61	4,600
1,000	38.2	2,750	8.0	2.9	66	5,500
1,200	43.0	3,290	8.0	3.0	71	6,800

Table 5

AL-XCTP AL/XLPE/CTS/PVC (Three Core)

XLPE Insulated, PVC Sheathed Cable 3.8/6.6KV (Max 7.2), IEC 60502-2

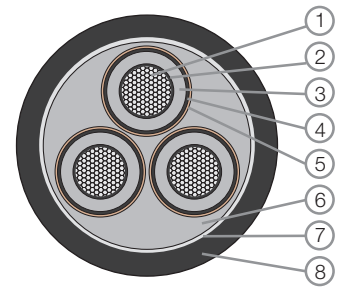
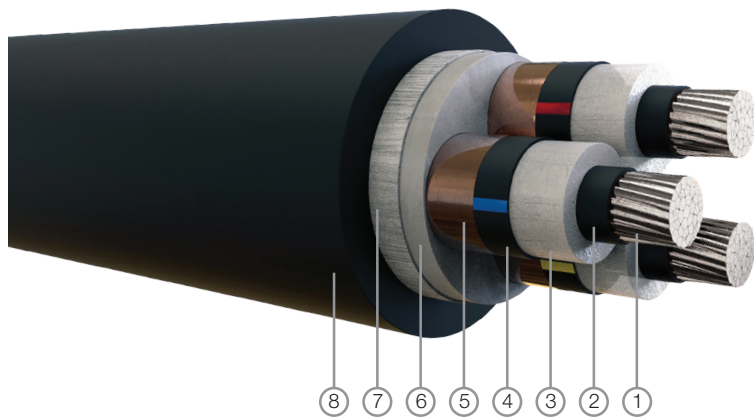

- Component**
1. Conductor
 2. Conductor screen
 3. Insulation
 4. Insulation screen
 5. Metallic screen (copper wire or copper tape)
 6. Yarn fillers
 7. Binder tape
 8. Outer sheath

CONSTRUCTION

Conductor:	Plain Annealed Aluminium, Class 2 Conductor
Conductor Screen	Extruded Semi Conductive Compound
Insulation:	Cross-linked Polyethylene (XLPE) Compound
Insulation Screen:	Extruded Semi Conductive Compound
Metallic Screen:	Copper Tape Screen
Assembled Core:	PP Yarn Filler with Binder Tape
Outer Sheath:	Polyvinyl Chloride (PVC) Compound Type ST2
Outer Sheath Colour:	Black (other colours upon request)

ELECTRICAL CHARACTERISTICS

Operating Voltage:	3.8/6.6KV
Conductor Operating Temperature:	90°C
Final Short Circuit Temperature:	250°C
Test Voltage:	3.5U ₀

AL/XLPE/CTS/PVC (Three Core)

Nominal Area of Conductor (mm ²)	Nominal Diameter of Conductor (mm)	Approximate Weight of Conductor (kg/km)	Nominal Thickness of Insulation (mm)	Nominal Thickness of Outer Sheath (mm)	Approximate Overall Diameter (mm)	Approximate Cable Weight (kg/km)
50	8.2	383	2.5	2.2	44	1,900
70	9.7	557	2.5	2.3	47	2,200
95	11.3	768	2.5	2.5	51	2,600
120	12.8	970	2.5	2.6	54	3,100
150	14.2	1,193	2.5	2.7	57	3,500
185	15.9	1,509	2.5	2.8	61	3,900
240	18.3	1,974	2.6	3.0	67	4,800
300	20.3	2,457	2.8	3.2	73	5,500
400	23.2	3,142	3.0	3.4	81	7,500

Table 6

AL-XCTP AL/XLPE/CTS/PVC (Three Core)

XLPE Insulated, PVC Sheathed Cable 6.35/11KV (Max 12), IEC 60502-2

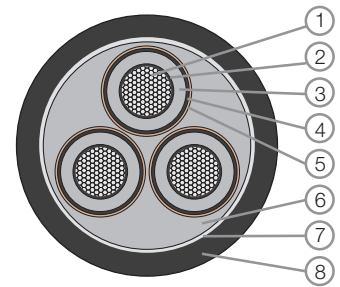
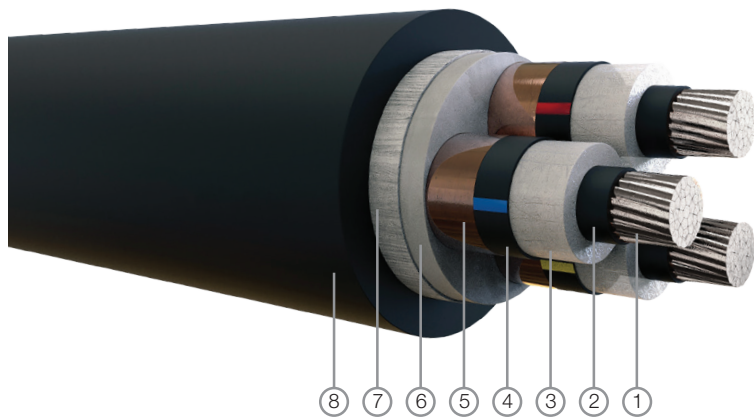

- Component**
1. Conductor
 2. Conductor screen
 3. Insulation
 4. Insulation screen
 5. Metallic screen (copper wire or copper tape)
 6. Yarn fillers
 7. Binder tape
 8. Outer sheath

CONSTRUCTION

Conductor:	Plain Annealed Aluminium, Class 2 Conductor
Conductor Screen	Extruded Semi Conductive Compound
Insulation:	Cross-linked Polyethylene (XLPE) Compound
Insulation Screen:	Extruded Semi Conductive Compound
Metallic Screen:	Copper Tape Screen
Assembled Core:	PP Yarn Filler with Binder Tape
Outer Sheath:	Polyvinyl Chloride (PVC) Compound Type ST2
Outer Sheath Colour:	Black (other colours upon request)

ELECTRICAL CHARACTERISTICS

Operating Voltage:	6.35/11KV
Conductor Operating Temperature:	90°C
Final Short Circuit Temperature:	250°C
Test Voltage:	3.5U ₀

AL/XLPE/CTS/PVC (Three Core)

Nominal Area of Conductor (mm ²)	Nominal Diameter of Conductor (mm)	Approximate Weight of Conductor (kg/km)	Nominal Thickness of Insulation (mm)	Nominal Thickness of Outer Sheath (mm)	Approximate Overall Diameter (mm)	Approximate Cable Weight (kg/km)
50	8.2	383	3.4	2.4	48	2,100
70	9.7	557	3.4	2.5	51	2,500
95	11.3	768	3.4	2.6	55	2,700
120	12.8	970	3.4	2.7	58	3,400
150	14.2	1,193	3.4	2.8	62	3,700
185	15.9	1,509	3.4	2.9	66	4,400
240	18.3	1,974	3.4	3.1	71	5,200
300	20.3	2,457	3.4	3.3	76	6,300
400	23.2	3,142	3.4	3.5	83	7,800

Table 7

AL-XCTP AL/XLPE/CTS/PVC (Three Core)

XLPE Insulated, PVC Sheathed Cable 8.7/15KV (Max 17.5), IEC 60502-2

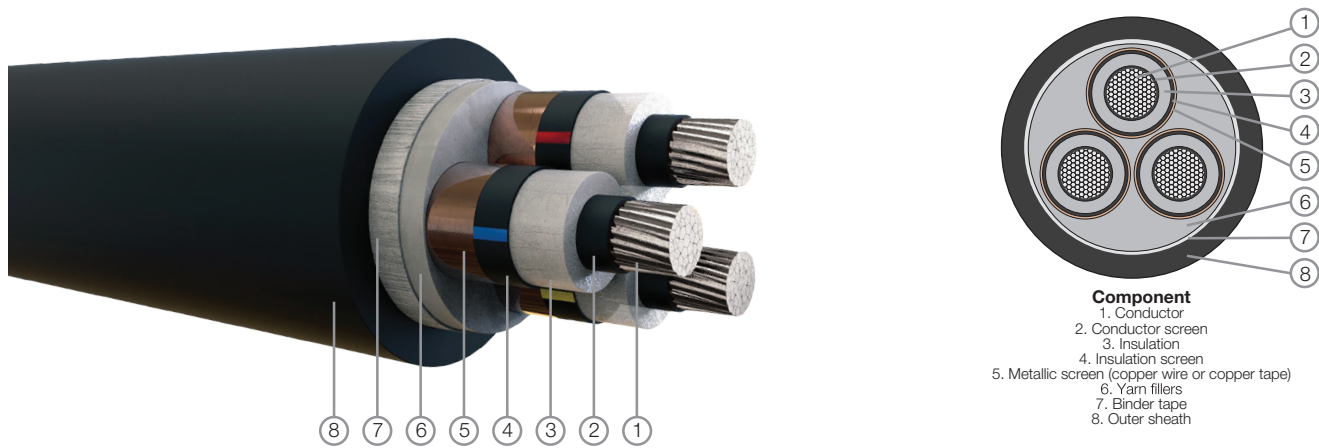

CONSTRUCTION

Conductor:	Plain Annealed Aluminium, Class 2 Conductor
Conductor Screen	Extruded Semi Conductive Compound
Insulation:	Cross-linked Polyethylene (XLPE) Compound
Insulation Screen:	Extruded Semi Conductive Compound
Metallic Screen:	Copper Tape Screen
Assembled Core:	PP Yarn Filler with Binder Tape
Outer Sheath:	Polyvinyl Chloride (PVC) Compound Type ST2
Outer Sheath Colour:	Black (other colours upon request)

ELECTRICAL CHARACTERISTICS

Operating Voltage:	8.7/15KV
Conductor Operating Temperature:	90°C
Final Short Circuit Temperature:	250°C
Test Voltage:	3.5U ₀

AL/XLPE/CTS/PVC (Three Core)

Nominal Area of Conductor (mm ²)	Nominal Diameter of Conductor (mm)	Approximate Weight of Conductor (kg/km)	Nominal Thickness of Insulation (mm)	Nominal Thickness of Outer Sheath (mm)	Approximate Overall Diameter (mm)	Approximate Cable Weight (kg/km)
50	8.2	383	4.5	2.6	53	2,600
70	9.7	557	4.5	2.7	57	2,900
95	11.3	768	4.5	2.8	60	3,400
120	12.8	970	4.5	2.9	64	5,200
150	14.2	1,193	4.5	3.0	67	4,400
185	15.9	1,509	4.5	3.1	71	4,900
240	18.3	1,974	4.5	3.3	76	5,600
300	20.3	2,457	4.5	3.4	81	6,800
400	23.2	3,142	4.5	3.7	87	8,200

Table 8

AL-XCTP AL/XLPE/CTS/PVC (Three Core)

XLPE Insulated, PVC Sheathed Cable 12.7/22KV (Max 24), IEC 60502-2

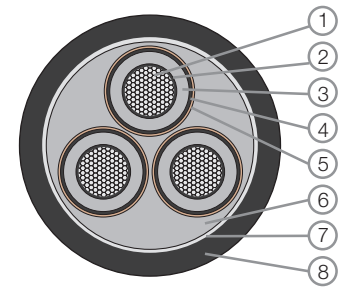
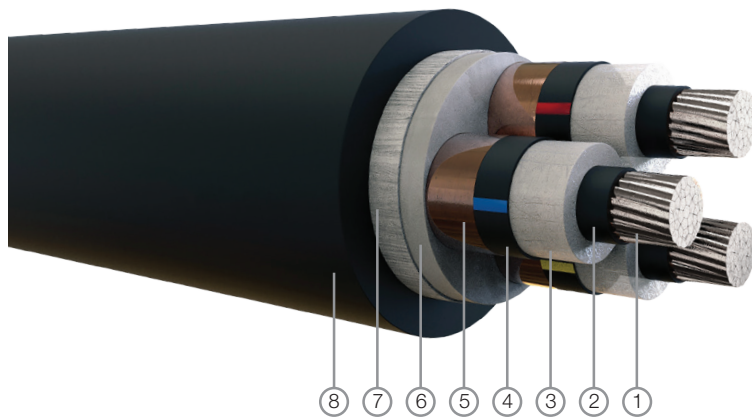

- Component**
1. Conductor
 2. Conductor screen
 3. Insulation
 4. Insulation screen
 5. Metallic screen (copper wire or copper tape)
 6. Yarn fillers
 7. Binder tape
 8. Outer sheath

CONSTRUCTION

Conductor:	Plain Annealed Aluminium, Class 2 Conductor
Conductor Screen	Extruded Semi Conductive Compound
Insulation:	Cross-linked Polyethylene (XLPE) Compound
Insulation Screen:	Extruded Semi Conductive Compound
Metallic Screen:	Copper Tape Screen
Assembled Core:	PP Yarn Filler with Binder Tape
Outer Sheath:	Polyvinyl Chloride (PVC) Compound Type ST2
Outer Sheath Colour:	Black (other colours upon request)

ELECTRICAL CHARACTERISTICS

Operating Voltage:	12.7/22KV
Conductor Operating Temperature:	90°C
Final Short Circuit Temperature:	250°C
Test Voltage:	3.5U ₀

AL/XLPE/CTS/PVC (Three Core)

Nominal Area of Conductor (mm ²)	Nominal Diameter of Conductor (mm)	Approximate Weight of Conductor (kg/km)	Nominal Thickness of Insulation (mm)	Nominal Thickness of Outer Sheath (mm)	Approximate Overall Diameter (mm)	Approximate Cable Weight (kg/km)
50	8.2	383	5.5	2.7	57	3,000
70	9.7	557	5.5	2.8	61	3,300
95	11.3	768	5.5	2.9	65	3,700
120	12.8	970	5.5	3.0	68	4,200
150	14.2	1,193	5.5	3.1	72	4,800
185	15.9	1,509	5.5	3.3	76	5,600
240	18.3	1,974	5.5	3.4	81	6,500
300	20.3	2,457	5.5	3.6	90	7,800
400	23.2	3,142	5.5	3.8	96	8,700

Table 9

AL-XCTP AL/XLPE/CTS/PVC (Three Core)

XLPE Insulated, PVC Sheathed Cable 19/33KV (Max 36), IEC 60502-2

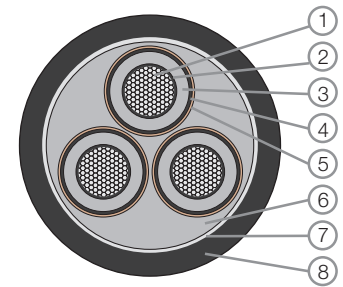
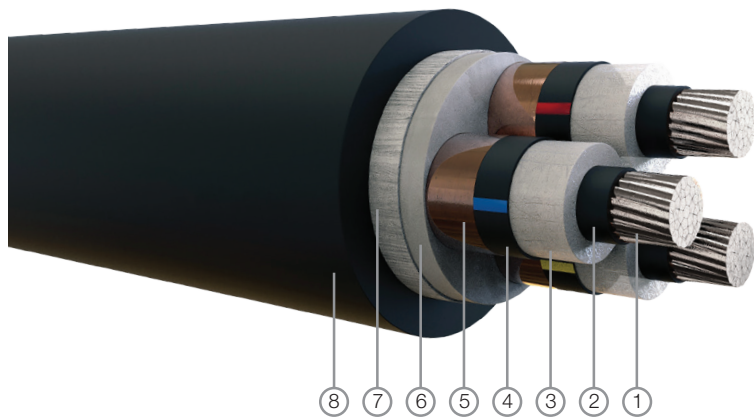

- Component**
1. Conductor
 2. Conductor screen
 3. Insulation
 4. Insulation screen
 5. Metallic screen (copper wire or copper tape)
 6. Yarn fillers
 7. Binder tape
 8. Outer sheath

CONSTRUCTION

Conductor:	Plain Annealed Aluminium, Class 2 Conductor
Conductor Screen	Extruded Semi Conductive Compound
Insulation:	Cross-linked Polyethylene (XLPE) Compound
Insulation Screen:	Extruded Semi Conductive Compound
Metallic Screen:	Copper Tape Screen
Assembled Core:	PP Yarn Filler with Binder Tape
Outer Sheath:	Polyvinyl Chloride (PVC) Compound Type ST2
Outer Sheath Colour:	Black (other colours upon request)

ELECTRICAL CHARACTERISTICS

Operating Voltage:	19/33KV
Conductor Operating Temperature:	90°C
Final Short Circuit Temperature:	250°C
Test Voltage:	3.5U ₀

AL/XLPE/CTS/PVC (Three Core)

Nominal Area of Conductor (mm ²)	Nominal Diameter of Conductor (mm)	Approximate Weight of Conductor (kg/km)	Nominal Thickness of Insulation (mm)	Nominal Thickness of Outer Sheath (mm)	Approximate Overall Diameter (mm)	Approximate Cable Weight (kg/km)
50	8.2	383	8.0	3.1	69	5,100
70	9.7	557	8.0	3.2	73	6,000
95	11.3	768	8.0	3.3	77	7,000
120	12.8	970	8.0	3.4	80	8,000
150	14.2	1,193	8.0	3.5	83	9,100
185	15.9	1,509	8.0	3.6	87	10,500
240	18.3	1,974	8.0	3.8	93	12,500
300	20.3	2,457	8.0	4.0	101	15,500
400	23.2	3,142	8.0	4.2	108	18,300

Table 10

AL-XCTAP AL/XLPE/CTS/PVC/AWA/PVC (Single Core)

XLPE Insulated, PVC Bedded, Aluminium Wire Armoured, PVC Sheathed Cable
3.8/6.6KV (Max 7.2), IEC 60502-2

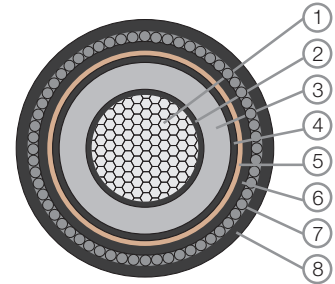
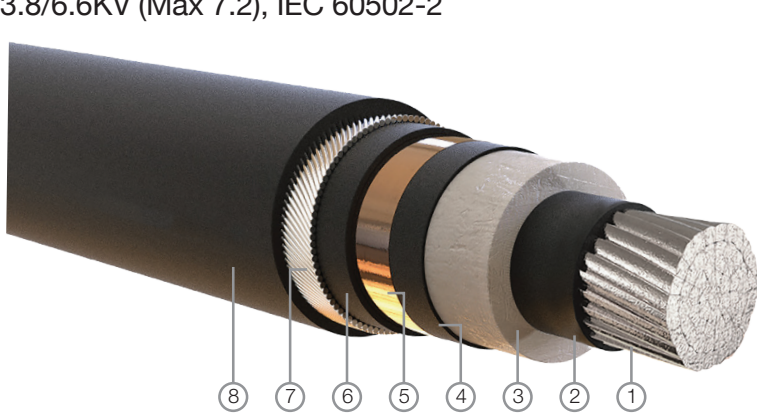

- Component**
1. Conductor
 2. Conductor screen
 3. Insulation
 4. Insulation screen
 5. Metallic screen (copper wire or copper tape)
 6. Inner sheath
 7. Armour
 8. Outer sheath

CONSTRUCTION

Conductor:	Plain Annealed Aluminium, Class 2 Conductor
Conductor Screen:	Extruded Semi Conductive Compound
Insulation:	Cross-linked Polyethylene (XLPE) Compound
Insulation Screen:	Extruded Semi Conductive Compound
Metallic Screen:	Copper Tape Screen
Inner Sheath:	Polyvinyl Chloride (PVC) Compound
Armour:	Aluminium Wire Armour (AWA) (DATA upon request)
Outer Sheath:	Polyvinyl Chloride (PVC) Compound Type ST2
Outer Sheath Colour:	Black (other colours upon request)

ELECTRICAL CHARACTERISTICS

Operating Voltage:	3.8/6.6KV
Conductor Operating Temperature:	90°C
Final Short Circuit Temperature:	250°C
Test Voltage:	3.5U ₀

AL/XLPE/CTS/PVC/AWA/PVC (Single Core)

Nominal Area of Conductor (mm ²)	Nominal Diameter of Conductor (mm)	Approximate Weight of Conductor (kg/km)	Nominal Thickness of Insulation (mm)	Nominal Thickness of Inner Sheath (mm)	Nominal Armour Wire Diameter (mm)	Nominal Thickness of Outer Sheath (mm)	Approximate Overall Diameter (mm)	Approximate Cable Weight (kg/km)
70	9.7	182	2.5	1.2	1.6	1.8	31	1,100
95	11.3	251	2.5	1.2	1.6	1.9	33	1,200
120	12.8	317	2.5	1.2	1.6	1.9	34	1,300
150	14.2	390	2.5	1.2	1.6	2.0	36	1,500
185	15.9	493	2.5	1.2	2.0	2.0	38	1,700
240	18.3	645	2.6	1.2	2.0	2.1	41	2,000
300	20.3	803	2.8	1.2	2.0	2.2	44	2,300
400	23.2	1,027	3.0	1.2	2.0	2.3	47	2,700
500	26.2	1,305	3.2	1.3	2.5	2.5	52	3,300
630	30.0	1,720	3.2	1.4	2.5	2.6	57	4,000
800	34.0	2,200	3.2	1.4	2.5	2.7	61	4,700
1,000	38.2	2,750	3.2	1.5	2.5	2.9	66	5,500
1,200	43.0	3,290	3.2	1.6	2.5	3.0	71	6,400

Table 11

AL-XCTAP AL/XLPE/CTS/PVC/AWA/PVC (Single Core)

XLPE Insulated, PVC Bedded, Aluminium Wire Armoured, PVC Sheathed Cable
6.35/11KV (Max 12), IEC 60502-2

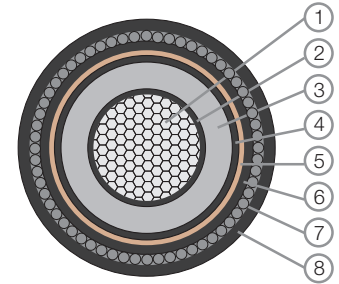
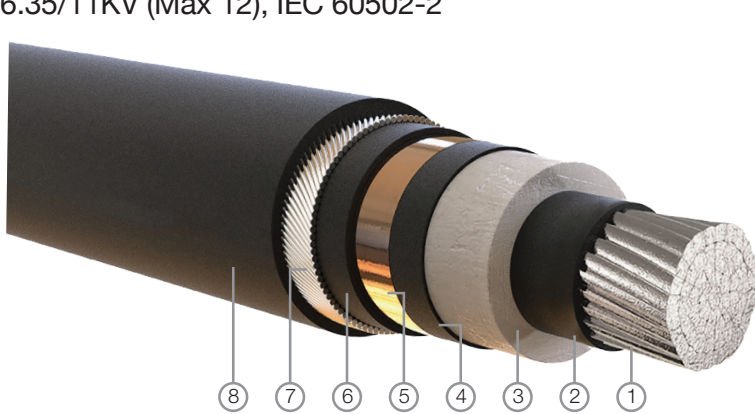

- Component**
1. Conductor
 2. Conductor screen
 3. Insulation
 4. Insulation screen
 5. Metallic screen (copper wire or copper tape)
 6. Inner sheath
 7. Armour
 8. Outer sheath

CONSTRUCTION

Conductor:	Plain Annealed Aluminium, Class 2 Conductor
Conductor Screen:	Extruded Semi Conductive Compound
Insulation:	Cross-linked Polyethylene (XLPE) Compound
Insulation Screen:	Extruded Semi Conductive Compound
Metallic Screen:	Copper Tape Screen
Inner Sheath:	Polyvinyl Chloride (PVC) Compound
Armour:	Aluminium Wire Armour (AWA) (DATA upon request)
Outer Sheath:	Polyvinyl Chloride (PVC) Compound Type ST2
Outer Sheath Colour:	Black (other colours upon request)

ELECTRICAL CHARACTERISTICS

Operating Voltage:	6.35/11KV
Conductor Operating Temperature:	90°C
Final Short Circuit Temperature:	250°C
Test Voltage:	3.5U ₀

AL/XLPE/CTS/PVC/AWA/PVC (Single Core)

Nominal Area of Conductor (mm ²)	Nominal Diameter of Conductor (mm)	Approximate Weight of Conductor (kg/km)	Nominal Thickness of Insulation (mm)	Nominal Thickness of Inner Sheath (mm)	Nominal Armour Wire Diameter (mm)	Nominal Thickness of Outer Sheath (mm)	Approximate Overall Diameter (mm)	Approximate Cable Weight (kg/km)
70	9.7	182	3.4	1.2	1.6	1.9	33	1,200
95	11.3	251	3.4	1.2	1.6	1.9	34	1,300
120	12.8	317	3.4	1.2	1.6	2.0	36	1,500
150	14.2	390	3.4	1.2	2.0	2.1	38	1,600
185	15.9	493	3.4	1.2	2.0	2.1	40	1,900
240	18.3	645	3.4	1.2	2.0	2.2	43	2,100
300	20.3	803	3.4	1.2	2.0	2.2	45	2,400
400	23.2	1,027	3.4	1.2	2.0	2.4	48	2,800
500	26.2	1,305	3.4	1.3	2.5	2.5	52	3,400
630	30.0	1,720	3.4	1.4	2.5	2.6	57	4,100
800	34.0	2,200	3.4	1.4	2.5	2.7	61	4,700
1,000	38.2	2,750	3.4	1.5	2.5	2.9	66	5,600
1,200	43.0	3,290	3.4	1.6	2.5	3.0	72	6,400

Table 12

AL-XCTAP AL/XLPE/CTS/PVC/AWA/PVC (Single Core)

XLPE Insulated, PVC Bedded, Aluminium Wire Armoured, PVC Sheathed Cable
8.7/15KV (Max 17.5), IEC 60502-2

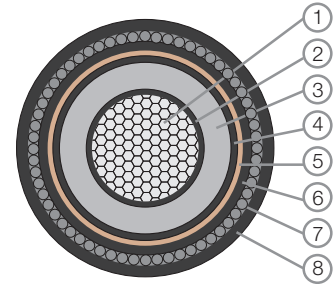
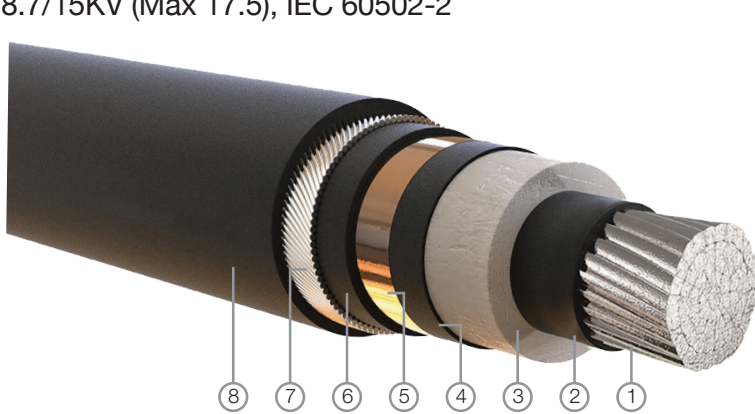

- Component**
1. Conductor
 2. Conductor screen
 3. Insulation
 4. Insulation screen
 5. Metallic screen (copper wire or copper tape)
 6. Inner sheath
 7. Armour
 8. Outer sheath

CONSTRUCTION

Conductor:	Plain Annealed Aluminium, Class 2 Conductor
Conductor Screen:	Extruded Semi Conductive Compound
Insulation:	Cross-linked Polyethylene (XLPE) Compound
Insulation Screen:	Extruded Semi Conductive Compound
Metallic Screen:	Copper Tape Screen
Inner Sheath:	Polyvinyl Chloride (PVC) Compound
Armour:	Aluminium Wire Armour (AWA) (DATA upon request)
Outer Sheath:	Polyvinyl Chloride (PVC) Compound Type ST2
Outer Sheath Colour:	Black (other colours upon request)

ELECTRICAL CHARACTERISTICS

Operating Voltage:	8.7/15KV
Conductor Operating Temperature:	90°C
Final Short Circuit Temperature:	250°C
Test Voltage:	3.5U ₀

AL/XLPE/CTS/PVC/AWA/PVC (Single Core)

Nominal Area of Conductor (mm ²)	Nominal Diameter of Conductor (mm)	Approximate Weight of Conductor (kg/km)	Nominal Thickness of Insulation (mm)	Nominal Thickness of Inner Sheath (mm)	Nominal Armour Wire Diameter (mm)	Nominal Thickness of Outer Sheath (mm)	Approximate Overall Diameter (mm)	Approximate Cable Weight (kg/km)
70	9.7	182	4.5	1.2	1.6	1.9	35	1,300
95	11.3	251	4.5	1.2	2.0	2.0	38	1,500
120	12.8	317	4.5	1.2	2.0	2.1	40	1,700
150	14.2	390	4.5	1.2	2.0	2.1	41	1,850
185	15.9	493	4.5	1.2	2.0	2.2	43	2,000
240	18.3	645	4.5	1.2	2.0	2.3	46	2,300
300	20.3	803	4.5	1.2	2.0	2.3	48	2,600
400	23.2	1,027	4.5	1.3	2.5	2.5	53	3,100
500	26.2	1,305	4.5	1.3	2.5	2.6	56	3,600
630	30.0	1,720	4.5	1.4	2.5	2.7	60	4,300
800	34.0	2,200	4.5	1.5	2.5	2.8	65	5,000
1,000	38.2	2,750	4.5	1.6	2.5	3.0	69	5,900
1,200	43.0	3,290	4.5	1.7	2.5	3.2	75	6,800

Table 13

AL-XCTAP AL/XLPE/CTS/PVC/AWA/PVC (Single Core)

XLPE Insulated, PVC Bedded, Aluminium Wire Armoured, PVC Sheathed Cable

12.7/22KV (Max 24), IEC 60502-2

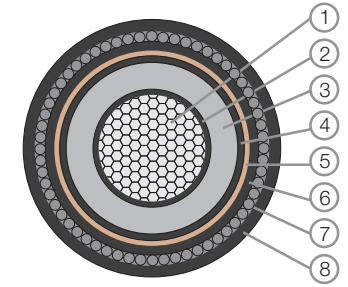

Component

- 1. Conductor
- 2. Conductor screen
- 3. Insulation
- 4. Insulation screen
- 5. Metallic screen (copper wire or copper tape)
- 6. Inner sheath
- 7. Armour
- 8. Outer sheath

CONSTRUCTION

Conductor:	Plain Annealed Aluminium, Class 2 Conductor
Conductor Screen:	Extruded Semi Conductive Compound
Insulation:	Cross-linked Polyethylene (XLPE) Compound
Insulation Screen:	Extruded Semi Conductive Compound
Metallic Screen:	Copper Tape Screen
Inner Sheath:	Polyvinyl Chloride (PVC) Compound
Armour:	Aluminium Wire Armour (AWA) (DATA upon request)
Outer Sheath:	Polyvinyl Chloride (PVC) Compound Type ST2
Outer Sheath Colour:	Black (other colours upon request)

ELECTRICAL CHARACTERISTICS

Operating Voltage:	12.7/22KV
Conductor Operating Temperature:	90°C
Final Short Circuit Temperature:	250°C
Test Voltage:	3.5U ₀

AL/XLPE/CTS/PVC/AWA/PVC (Single Core)

Nominal Area of Conductor (mm ²)	Nominal Diameter of Conductor (mm)	Approximate Weight of Conductor (kg/km)	Nominal Thickness of Insulation (mm)	Nominal Thickness of Inner Sheath (mm)	Nominal Armour Wire Diameter (mm)	Nominal Thickness of Outer Sheath (mm)	Approximate Overall Diameter (mm)	Approximate Cable Weight (kg/km)
70	9.7	182	5.5	1.2	2.0	2.0	38	1,500
95	11.3	251	5.5	1.2	2.0	2.1	40	1,700
120	12.8	317	5.5	1.2	2.0	2.1	42	1,800
150	14.2	390	5.5	1.2	2.0	2.2	43	2,000
185	15.9	493	5.5	1.2	2.0	2.2	45	2,200
240	18.3	645	5.5	1.2	2.0	2.3	48	2,500
300	20.3	803	5.5	1.3	2.5	2.4	51	2,900
400	23.2	1,027	5.5	1.3	2.5	2.5	54	3,300
500	26.2	1,305	5.5	1.4	2.5	2.6	58	3,800
630	30.0	1,720	5.5	1.4	2.5	2.8	62	4,500
800	34.0	2,200	5.5	1.5	2.5	2.9	66	5,300
1,000	38.2	2,750	5.5	1.6	2.5	3.0	71	6,100
1,200	43.0	3,290	5.5	1.7	2.5	3.2	77	7,000

Table 14

AL-XCTAP AL/XLPE/CTS/PVC/AWA/PVC (Single Core)

XLPE Insulated, PVC Bedded, Aluminium Wire Armoured, PVC Sheathed Cable
19/33KV (Max 36), IEC 60502-2

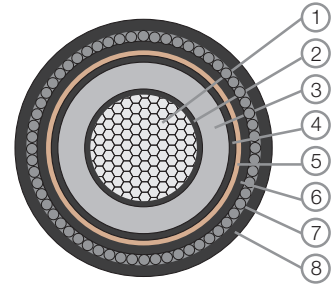
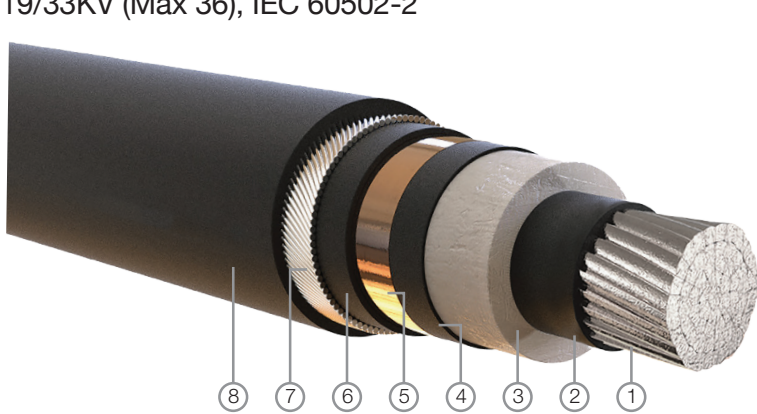

- Component**
1. Conductor
 2. Conductor screen
 3. Insulation
 4. Insulation screen
 5. Metallic screen (copper wire or copper tape)
 6. Inner sheath
 7. Armour
 8. Outer sheath

CONSTRUCTION

Conductor:	Plain Annealed Aluminium, Class 2 Conductor
Conductor Screen:	Extruded Semi Conductive Compound
Insulation:	Cross-linked Polyethylene (XLPE) Compound
Insulation Screen:	Extruded Semi Conductive Compound
Metallic Screen:	Copper Tape Screen
Inner Sheath:	Polyvinyl Chloride (PVC) Compound
Armour:	Aluminium Wire Armour (AWA) (DATA upon request)
Outer Sheath:	Polyvinyl Chloride (PVC) Compound Type ST2
Outer Sheath Colour:	Black (other colours upon request)

ELECTRICAL CHARACTERISTICS

Operating Voltage:	19/33KV
Conductor Operating Temperature:	90°C
Final Short Circuit Temperature:	250°C
Test Voltage:	3.5U ₀

AL/XLPE/CTS/PVC/AWA/PVC (Single Core)

Nominal Area of Conductor (mm ²)	Nominal Diameter of Conductor (mm)	Approximate Weight of Conductor (kg/km)	Nominal Thickness of Insulation (mm)	Nominal Thickness of Inner Sheath (mm)	Nominal Armour Wire Diameter (mm)	Nominal Thickness of Outer Sheath (mm)	Approximate Overall Diameter (mm)	Approximate Cable Weight (kg/km)
70	9.7	182	8.0	1.2	2.0	2.2	43	1,900
95	11.3	251	8.0	1.2	2.0	2.3	45	2,100
120	12.8	317	8.0	1.2	2.0	2.3	47	2,200
150	14.2	390	8.0	1.3	2.0	2.4	48	2,400
185	15.9	493	8.0	1.3	2.5	2.5	51	2,900
240	18.3	645	8.0	1.3	2.5	2.5	54	3,240
300	20.3	803	8.0	1.4	2.5	2.6	56	3,600
400	23.2	1,027	8.0	1.4	2.5	2.7	59	4,100
500	26.2	1,305	8.0	1.5	2.5	2.8	63	4,600
630	30.0	1,720	8.0	1.5	2.5	2.9	67	5,400
800	34.0	2,200	8.0	1.6	2.5	3.1	71	6,200
1,000	38.2	2,750	8.0	1.7	2.5	3.2	76	7,500
1,200	43.0	3,290	8.0	1.8	2.5	3.3	81	8,700

Table 15

AL-XCTDAP AL/XLPE/CTS/PVC/DATA/PVC (Single Core)

XLPE Insulated, PVC Bedded, Double Aluminium Tape Armoured, PVC Sheathed Cable 3.8/6.6KV (Max 7.2), IEC 60502-2

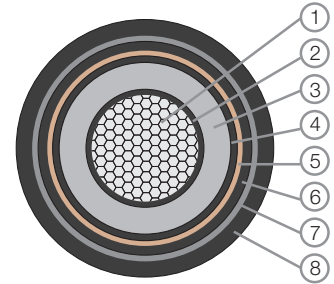
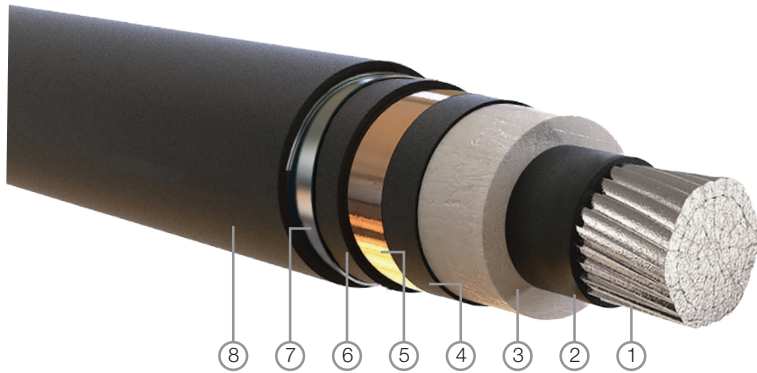

- Component**
1. Conductor
 2. Conductor screen
 3. Insulation
 4. Insulation screen
 5. Metallic screen (copper wire or copper tape)
 6. Inner sheath
 7. Armour
 8. Outer sheath

CONSTRUCTION

Conductor:	Plain Annealed Aluminium, Class 2 Conductor
Conductor Screen:	Extruded Semi Conductive Compound
Insulation:	Cross-linked Polyethylene (XLPE) Compound
Insulation Screen:	Extruded Semi Conductive Compound
Metallic Screen:	Copper Tape Screen
Inner Sheath:	Polyvinyl Chloride (PVC) Compound
Armour:	Double Aluminium Tape Armour (DATA)
Outer Sheath:	Polyvinyl Chloride (PVC) Compound Type ST2
Outer Sheath Colour:	Black (other colours upon request)

ELECTRICAL CHARACTERISTICS

Operating Voltage:	3.8/6.6KV
Conductor Operating Temperature:	90°C
Final Short Circuit Temperature:	250°C
Test Voltage:	3.5U ₀

AL/XLPE/CTS/PVC/DATA/PVC (Single Core)

Nominal Area of Conductor (mm ²)	Nominal Diameter of Conductor (mm)	Approximate Weight of Conductor (kg/km)	Nominal Thickness of Insulation (mm)	Nominal Thickness of Inner Sheath (mm)	Nominal Thickness of Aluminium Tape (mm)	Nominal Thickness of Outer Sheath (mm)	Approximate Overall Diameter (mm)	Approximate Cable Weight (kg/km)
70	9.7	182	2.5	1.2	0.5	1.8	29	980
95	11.3	251	2.5	1.2	0.5	1.9	31	1,100
120	12.8	317	2.5	1.2	0.5	1.9	33	1,200
150	14.2	390	2.5	1.2	0.5	2.0	35	1,300
185	15.9	493	2.5	1.2	0.5	2.0	36	1,500
240	18.3	645	2.6	1.2	0.5	2.1	39	1,700
300	20.3	803	2.8	1.2	0.5	2.2	42	2,000
400	23.2	1,027	3.0	1.2	0.5	2.3	46	2,300
500	26.2	1,305	3.2	1.3	0.5	2.5	49	2,800
630	30.0	1,720	3.2	1.4	0.5	2.6	54	3,500
800	34.0	2,200	3.2	1.4	0.5	2.7	58	4,000
1,000	38.2	2,750	3.2	1.5	0.5	2.9	63	4,800
1,200	43.0	3,290	3.2	1.6	0.5	3.0	67	5,400

Table 16

AL-XCTDAP AL/XLPE/CTS/PVC/DATA/PVC (Single Core)

XLPE Insulated, PVC Bedded, Double Aluminium Tape Armoured, PVC Sheathed Cable 6.35/11KV (Max 12), IEC 60502-2

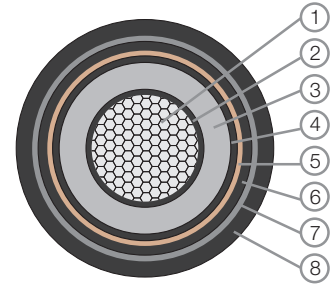
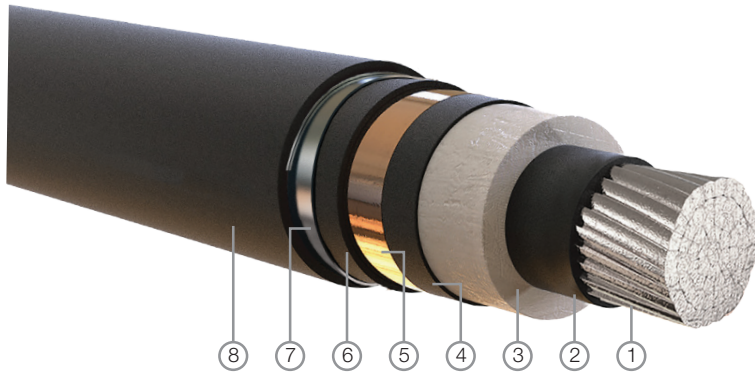

- Component**
1. Conductor
 2. Conductor screen
 3. Insulation
 4. Insulation screen
 5. Metallic screen (copper wire or copper tape)
 6. Inner sheath
 7. Armour
 8. Outer sheath

CONSTRUCTION

Conductor:	Plain Annealed Aluminium, Class 2 Conductor
Conductor Screen:	Extruded Semi Conductive Compound
Insulation:	Cross-linked Polyethylene (XLPE) Compound
Insulation Screen:	Extruded Semi Conductive Compound
Metallic Screen:	Copper Tape Screen
Inner Sheath:	Polyvinyl Chloride (PVC) Compound
Armour:	Double Aluminium Tape Armour (DATA)
Outer Sheath:	Polyvinyl Chloride (PVC) Compound Type ST2
Outer Sheath Colour:	Black (other colours upon request)

ELECTRICAL CHARACTERISTICS

Operating Voltage:	6.35/11KV
Conductor Operating Temperature:	90°C
Final Short Circuit Temperature:	250°C
Test Voltage:	3.5U ₀

AL/XLPE/CTS/PVC/DATA/PVC (Single Core)

Nominal Area of Conductor (mm ²)	Nominal Diameter of Conductor (mm)	Approximate Weight of Conductor (kg/km)	Nominal Thickness of Insulation (mm)	Nominal Thickness of Inner Sheath (mm)	Nominal Thickness of Aluminium Tape (mm)	Nominal Thickness of Outer Sheath (mm)	Approximate Overall Diameter (mm)	Approximate Cable Weight (kg/km)
70	9.7	182	3.4	1.2	0.5	1.9	31	1,000
95	11.3	251	3.4	1.2	0.5	1.9	33	1,200
120	12.8	317	3.4	1.2	0.5	2.0	35	1,300
150	14.2	390	3.4	1.2	0.5	2.1	37	1,400
185	15.9	493	3.4	1.2	0.5	2.1	38	1,600
240	18.3	645	3.4	1.2	0.5	2.2	41	1,800
300	20.3	803	3.4	1.2	0.5	2.2	43	2,100
400	23.2	1,027	3.4	1.2	0.5	2.4	47	2,400
500	26.2	1,305	3.4	1.3	0.5	2.5	50	2,900
630	30.0	1,720	3.4	1.4	0.5	2.6	55	3,600
800	34.0	2,200	3.4	1.4	0.5	2.7	59	4,100
1,000	38.2	2,750	3.4	1.5	0.5	2.9	64	4,900
1,200	43.0	3,290	3.4	1.6	0.5	3.0	68	5,500

Table 17

AL-XCTDAP AL/XLPE/CTS/PVC/DATA/PVC (Single Core)

XLPE Insulated, PVC Bedded, Double Aluminium Tape Armoured, PVC Sheathed Cable 8.7/15KV (Max 17.5), IEC 60502-2

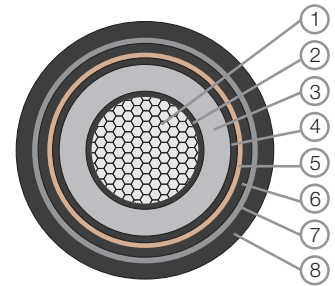
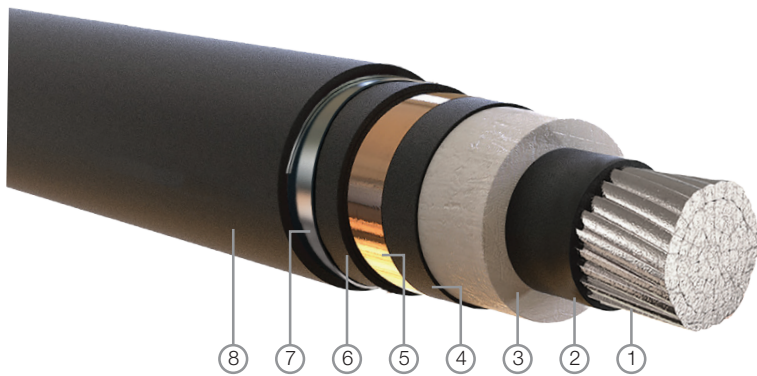

- Component**
1. Conductor
 2. Conductor screen
 3. Insulation
 4. Insulation screen
 5. Metallic screen (copper wire or copper tape)
 6. Inner sheath
 7. Armour
 8. Outer sheath

CONSTRUCTION

Conductor:	Plain Annealed Aluminium, Class 2 Conductor
Conductor Screen:	Extruded Semi Conductive Compound
Insulation:	Cross-linked Polyethylene (XLPE) Compound
Insulation Screen:	Extruded Semi Conductive Compound
Metallic Screen:	Copper Tape Screen
Inner Sheath:	Polyvinyl Chloride (PVC) Compound
Armour:	Double Aluminium Tape Armour (DATA)
Outer Sheath:	Polyvinyl Chloride (PVC) Compound Type ST2
Outer Sheath Colour:	Black (other colours upon request)

ELECTRICAL CHARACTERISTICS

Operating Voltage:	8.7/15KV
Conductor Operating Temperature:	90°C
Final Short Circuit Temperature:	250°C
Test Voltage:	3.5U ₀

AL/XLPE/CTS/PVC/DATA/PVC (Single Core)

Nominal Area of Conductor (mm ²)	Nominal Diameter of Conductor (mm)	Approximate Weight of Conductor (kg/km)	Nominal Thickness of Insulation (mm)	Nominal Thickness of Inner Sheath (mm)	Nominal Thickness of Aluminium Tape (mm)	Nominal Thickness of Outer Sheath (mm)	Approximate Overall Diameter (mm)	Approximate Cable Weight (kg/km)
70	9.7	182	4.5	1.2	0.5	1.9	33	1,200
95	11.3	251	4.5	1.2	0.5	2.0	35	1,300
120	12.8	317	4.5	1.2	0.5	2.1	37	1,500
150	14.2	390	4.5	1.2	0.5	2.1	39	1,600
185	15.9	493	4.5	1.2	0.5	2.2	41	1,800
240	18.3	645	4.5	1.2	0.5	2.3	43	2,000
300	20.3	803	4.5	1.2	0.5	2.3	45	2,300
400	23.2	1,027	4.5	1.3	0.5	2.5	49	2,600
500	26.2	1,305	4.5	1.3	0.5	2.6	52	3,000
630	30.0	1,720	4.5	1.4	0.5	2.7	56	3,700
800	34.0	2,200	4.5	1.5	0.5	2.8	61	4,300
1,000	38.2	2,750	4.5	1.6	0.5	3.0	66	5,100
1,200	43.0	3,290	4.5	1.7	0.5	3.2	70	5,800

Table 18

AL-XCTDAP AL/XLPE/CTS/PVC/DATA/PVC (Single Core)

XLPE Insulated, PVC Bedded, Double Aluminium Tape Armoured, PVC Sheathed Cable 12.7/22KV (Max 24), IEC 60502-2

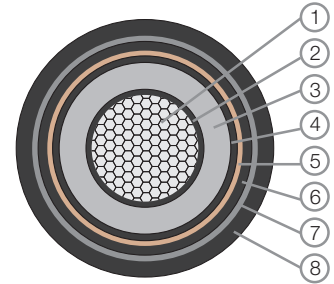
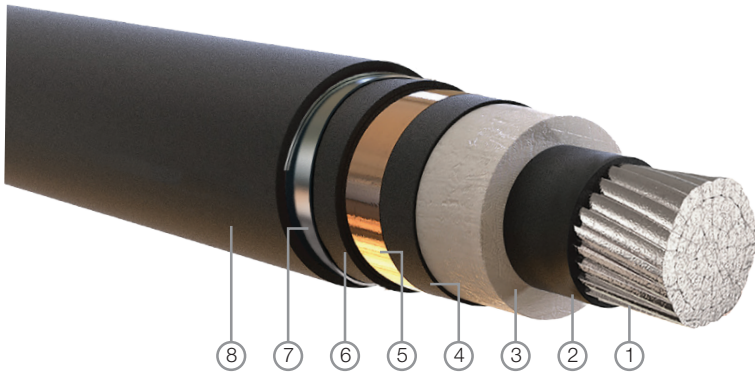

- Component**
1. Conductor
 2. Conductor screen
 3. Insulation
 4. Insulation screen
 5. Metallic screen (copper wire or copper tape)
 6. Inner sheath
 7. Armour
 8. Outer sheath

CONSTRUCTION

Conductor:	Plain Annealed Aluminium, Class 2 Conductor
Conductor Screen:	Extruded Semi Conductive Compound
Insulation:	Cross-linked Polyethylene (XLPE) Compound
Insulation Screen:	Extruded Semi Conductive Compound
Metallic Screen:	Copper Tape Screen
Inner Sheath:	Polyvinyl Chloride (PVC) Compound
Armour:	Double Aluminium Tape Armour (DATA)
Outer Sheath:	Polyvinyl Chloride (PVC) Compound Type ST2
Outer Sheath Colour:	Black (other colours upon request)

ELECTRICAL CHARACTERISTICS

Operating Voltage:	12.7/22KV
Conductor Operating Temperature:	90°C
Final Short Circuit Temperature:	250°C
Test Voltage:	3.5U ₀

AL/XLPE/CTS/PVC/DATA/PVC (Single Core)

Nominal Area of Conductor (mm ²)	Nominal Diameter of Conductor (mm)	Approximate Weight of Conductor (kg/km)	Nominal Thickness of Insulation (mm)	Nominal Thickness of Inner Sheath (mm)	Nominal Thickness of Aluminium Tape (mm)	Nominal Thickness of Outer Sheath (mm)	Approximate Overall Diameter (mm)	Approximate Cable Weight (kg/km)
70	9.7	182	5.5	1.2	0.5	2.0	37	1,400
95	11.3	251	5.5	1.2	0.5	2.1	39	1,500
120	12.8	317	5.5	1.2	0.5	2.1	40	1,600
150	14.2	390	5.5	1.2	0.5	2.2	42	1,800
185	15.9	493	5.5	1.2	0.5	2.2	44	2,000
240	18.3	645	5.5	1.2	0.5	2.3	46	2,200
300	20.3	803	5.5	1.3	0.5	2.4	49	2,500
400	23.2	1,027	5.5	1.3	0.5	2.5	52	2,900
500	26.2	1,305	5.5	1.4	0.5	2.6	55	3,300
630	30.0	1,720	5.5	1.4	0.5	2.8	60	4,000
800	34.0	2,200	5.5	1.5	0.5	2.9	64	4,600
1,000	38.2	2,750	5.5	1.6	0.5	3.0	69	5,400
1,200	43.0	3,290	5.5	1.7	0.5	3.2	73	6,100

Table 19

AL-XCTDAP AL/XLPE/CTS/PVC/DATA/PVC (Single Core)

XLPE Insulated, PVC Bedded, Double Aluminium Tape Armoured, PVC Sheathed Cable 19/33KV (Max 36), IEC 60502-2

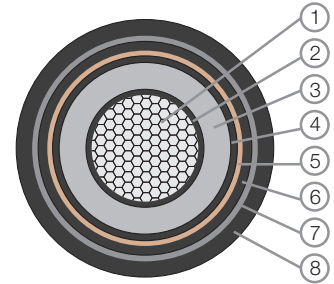
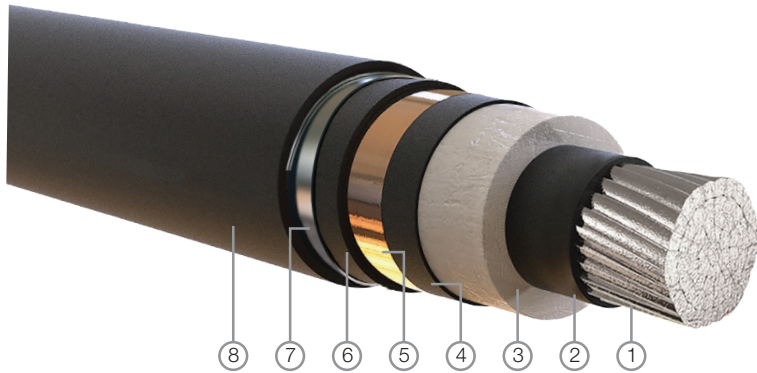

- Component**
1. Conductor
 2. Conductor screen
 3. Insulation
 4. Insulation screen
 5. Metallic screen (copper wire or copper tape)
 6. Inner sheath
 7. Armour
 8. Outer sheath

CONSTRUCTION

Conductor:	Plain Annealed Aluminium, Class 2 Conductor
Conductor Screen:	Extruded Semi Conductive Compound
Insulation:	Cross-linked Polyethylene (XLPE) Compound
Insulation Screen:	Extruded Semi Conductive Compound
Metallic Screen:	Copper Tape Screen
Inner Sheath:	Polyvinyl Chloride (PVC) Compound
Armour:	Double Aluminium Tape Armour (DATA)
Outer Sheath:	Polyvinyl Chloride (PVC) Compound Type ST2
Outer Sheath Colour:	Black (other colours upon request)

ELECTRICAL CHARACTERISTICS

Operating Voltage:	19/33KV
Conductor Operating Temperature:	90°C
Final Short Circuit Temperature:	250°C
Test Voltage:	3.5U ₀

AL/XLPE/CTS/PVC/DATA/PVC (Single Core)

Nominal Area of Conductor (mm ²)	Nominal Diameter of Conductor (mm)	Approximate Weight of Conductor (kg/km)	Nominal Thickness of Insulation (mm)	Nominal Thickness of Inner Sheath (mm)	Nominal Thickness of Aluminium Tape (mm)	Nominal Thickness of Outer Sheath (mm)	Approximate Overall Diameter (mm)	Approximate Cable Weight (kg/km)
70	9.7	182	8.0	1.2	0.5	2.2	42	1,700
95	11.3	251	8.0	1.2	0.5	2.3	44	1,900
120	12.8	317	8.0	1.2	0.5	2.3	46	2,000
150	14.2	390	8.0	1.3	0.5	2.4	48	2,200
185	15.9	493	8.0	1.3	0.5	2.5	59	2,400
240	18.3	645	8.0	1.3	0.5	2.5	52	2,700
300	20.3	803	8.0	1.4	0.5	2.6	54	3,000
400	23.2	1,027	8.0	1.4	0.5	2.7	58	3,300
500	26.2	1,305	8.0	1.5	0.5	2.8	61	3,800
630	30.0	1,720	8.0	1.5	0.5	2.9	65	4,500
800	34.0	2,200	8.0	1.6	0.5	3.1	69	5,200
1,000	38.2	2,750	8.0	1.7	0.5	3.2	74	6,000
1,200	43.0	3,290	8.0	1.8	0.5	3.3	78	6,700

Table 20

AL-XCTDP AL/XLPE/CTS/PVC/DSTA/PVC (Three Core)

XLPE Insulated, PVC Bedded, Double Steel Tape Armoured, PVC Sheathed Cable
3.8/6.6KV (Max 7.2), IEC 60502-2

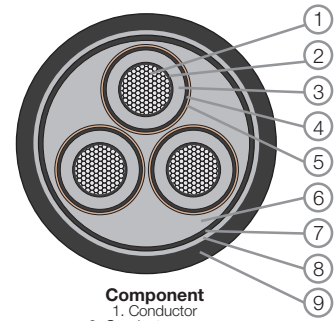
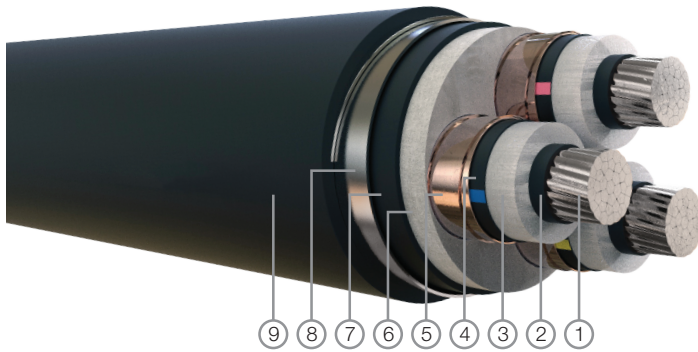

- Component**
1. Conductor
 2. Conductor screen
 3. Insulation
 4. Insulation screen
 5. Metallic screen (copper wire or copper tape)
 6. Filler & Binder Tape
 7. Inner sheath
 8. Armour
 9. Outer sheath

CONSTRUCTION

Conductor:	Plain Annealed Aluminium, Class 2 Conductor
Conductor Screen:	Extruded Semi Conductive Compound
Insulation:	Cross-linked Polyethylene (XLPE) Compound
Insulation Screen:	Extruded Semi Conductive Compound
Metallic Screen:	Copper Tape Screen
Assembled Core:	PP Yarn Filler with Binder Tape
Inner Sheath:	Polyvinyl Chloride (PVC) Compound
Armour:	Double Steel Tape Armour (DSTA)
Outer Sheath:	Polyvinyl Chloride (PVC) Compound Type ST2
Outer Sheath Colour:	Black (other colours upon request)

ELECTRICAL CHARACTERISTICS

Operating Voltage:	3.8/6.6KV
Conductor Operating Temperature:	90°C
Final Short Circuit Temperature:	250°C
Test Voltage:	3.5U ₀

AL/XLPE/CTS/PVC/DSTA/PVC (Three Core)

Nominal Area of Conductor (mm ²)	Nominal Diameter of Conductor (mm)	Approximate Weight of Conductor (kg/km)	Nominal Thickness of Insulation (mm)	Nominal Thickness of Inner Sheath (mm)	Nominal Thickness of Steel Tape (mm)	Nominal Thickness of Outer Sheath (mm)	Approximate Overall Diameter (mm)	Approximate Cable Weight (kg/km)
50	8.2	383	2.5	1.3	0.5	2.4	49	3,000
70	9.7	557	2.5	1.4	0.5	2.5	53	3,500
95	11.3	768	2.5	1.4	0.5	2.6	56	4,000
120	12.8	970	2.5	1.5	0.5	2.7	60	4,600
150	14.2	1,193	2.5	1.5	0.5	2.8	63	5,100
185	15.9	1,509	2.5	1.6	0.5	2.9	67	5,800
240	18.3	1,974	2.6	1.7	0.5	3.1	73	6,900
300	20.3	2,457	2.8	1.8	0.5	3.3	79	8,600
400	23.2	3,142	3.0	2.0	0.8	3.6	88	11,000

Table 21

AL-XCTDP AL/XLPE/CTS/PVC/DSTA/PVC (Three Core)

XLPE Insulated, PVC Bedded, Double Steel Tape Armoured, PVC Sheathed Cable
6.35/11KV (Max 12), IEC 60502-2

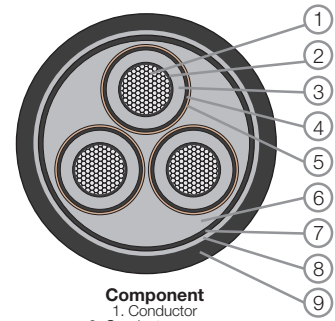
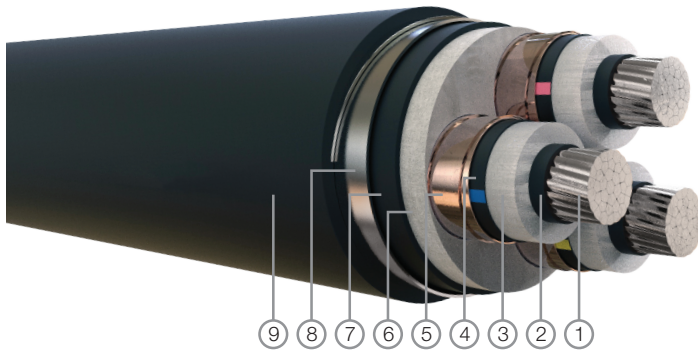

- Component**
1. Conductor
 2. Conductor screen
 3. Insulation
 4. Insulation screen
 5. Metallic screen (copper wire or copper tape)
 6. Filler & Binder Tape
 7. Inner sheath
 8. Armour
 9. Outer sheath

CONSTRUCTION

Conductor:	Plain Annealed Aluminium, Class 2 Conductor
Conductor Screen:	Extruded Semi Conductive Compound
Insulation:	Cross-linked Polyethylene (XLPE) Compound
Insulation Screen:	Extruded Semi Conductive Compound
Metallic Screen:	Copper Tape Screen
Assembled Core:	PP Yarn Filler with Binder Tape
Inner Sheath:	Polyvinyl Chloride (PVC) Compound
Armour:	Double Steel Tape Armour (DSTA)
Outer Sheath:	Polyvinyl Chloride (PVC) Compound Type ST2
Outer Sheath Colour:	Black (other colours upon request)

ELECTRICAL CHARACTERISTICS

Operating Voltage:	6.35/11KV
Conductor Operating Temperature:	90°C
Final Short Circuit Temperature:	250°C
Test Voltage:	3.5U ₀

AL/XLPE/CTS/PVC/DSTA/PVC (Three Core)

Nominal Area of Conductor (mm ²)	Nominal Diameter of Conductor (mm)	Approximate Weight of Conductor (kg/km)	Nominal Thickness of Insulation (mm)	Nominal Thickness of Inner Sheath (mm)	Nominal Thickness of Steel Tape (mm)	Nominal Thickness of Outer Sheath (mm)	Approximate Overall Diameter (mm)	Approximate Cable Weight (kg/km)
50	8.2	383	3.4	1.4	0.5	2.5	53	3,400
70	9.7	557	3.4	1.4	0.5	2.6	56	3,900
95	11.3	768	3.4	1.5	0.5	2.7	60	4,500
120	12.8	970	3.4	1.6	0.5	2.9	64	5,100
150	14.2	1,193	3.4	1.6	0.5	3.0	67	5,600
185	15.9	1,509	3.4	1.7	0.5	3.1	71	6,300
240	18.3	1,974	3.4	1.8	0.5	3.3	77	7,400
300	20.3	2,457	3.4	1.9	0.5	3.4	82	9,000
400	23.2	3,142	3.4	2.0	0.8	3.7	90	11,600

Table 22

AL-XCTDP AL/XLPE/CTS/PVC/DSTA/PVC (Three Core)

XLPE Insulated, PVC Bedded, Double Steel Tape Armoured, PVC Sheathed Cable
8.7/15KV (Max 17.5), IEC 60502-2

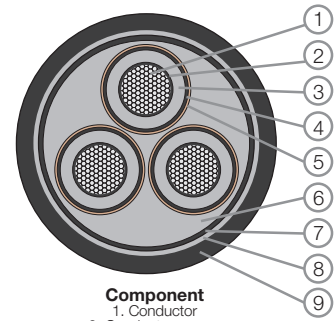
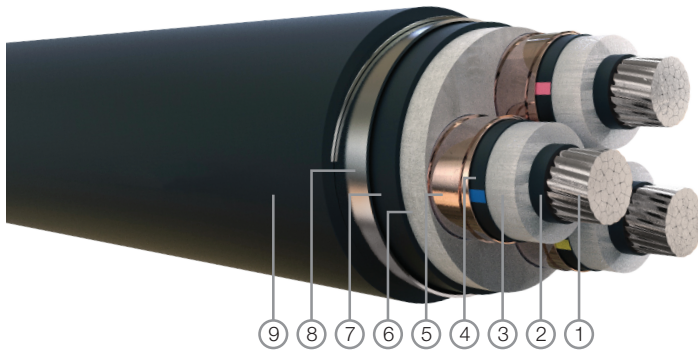

- Component**
1. Conductor
 2. Conductor screen
 3. Insulation
 4. Insulation screen
 5. Metallic screen (copper wire or copper tape)
 6. Filler & Binder Tape
 7. Inner sheath
 8. Armour
 9. Outer sheath

CONSTRUCTION

Conductor:	Plain Annealed Aluminium, Class 2 Conductor
Conductor Screen:	Extruded Semi Conductive Compound
Insulation:	Cross-linked Polyethylene (XLPE) Compound
Insulation Screen:	Extruded Semi Conductive Compound
Metallic Screen:	Copper Tape Screen
Assembled Core:	PP Yarn Filler with Binder Tape
Inner Sheath:	Polyvinyl Chloride (PVC) Compound
Armour:	Double Steel Tape Armour (DSTA)
Outer Sheath:	Polyvinyl Chloride (PVC) Compound Type ST2
Outer Sheath Colour:	Black (other colours upon request)

ELECTRICAL CHARACTERISTICS

Operating Voltage:	8.7/15KV
Conductor Operating Temperature:	90°C
Final Short Circuit Temperature:	250°C
Test Voltage:	3.5U ₀

AL/XLPE/CTS/PVC/DSTA/PVC (Three Core)

Nominal Area of Conductor (mm ²)	Nominal Diameter of Conductor (mm)	Approximate Weight of Conductor (kg/km)	Nominal Thickness of Insulation (mm)	Nominal Thickness of Inner Sheath (mm)	Nominal Thickness of Steel Tape (mm)	Nominal Thickness of Outer Sheath (mm)	Approximate Overall Diameter (mm)	Approximate Cable Weight (kg/km)
50	8.2	383	4.5	1.5	0.5	2.7	58	4,100
70	9.7	557	4.5	1.5	0.5	2.8	61	4,600
95	11.3	768	4.5	1.6	0.5	2.9	65	5,200
120	12.8	970	4.5	1.7	0.5	3.0	69	5,900
150	14.2	1,193	4.5	1.7	0.5	3.1	72	6,400
185	15.9	1,509	4.5	1.8	0.5	3.3	76	7,100
240	18.3	1,974	4.5	1.9	0.5	3.4	82	8,200
300	20.3	2,457	4.5	2.0	0.8	3.6	88	11,000
400	23.2	3,142	4.5	2.1	0.8	3.9	95	12,500

Table 23

AL-XCTDP AL/XLPE/CTS/PVC/DSTA/PVC (Three Core)

XLPE Insulated, PVC Bedded, Double Steel Tape Armoured, PVC Sheathed Cable
12.7/22KV (Max 24), IEC 60502-2

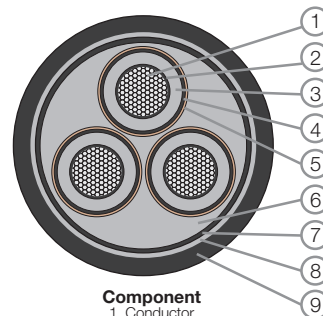
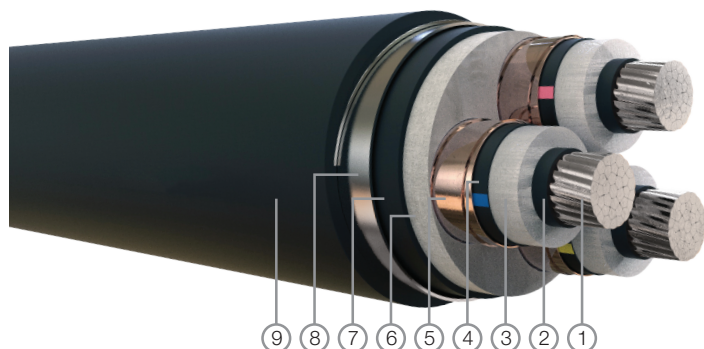

Component

- 1. Conductor
- 2. Conductor screen
- 3. Insulation
- 4. Insulation screen
- 5. Metallic screen (copper wire or copper tape)
- 6. Filler & Binder Tape
- 7. Inner sheath
- 8. Armour
- 9. Outer sheath

CONSTRUCTION

- Conductor: Plain Annealed Aluminium, Class 2 Conductor
- Conductor Screen: Extruded Semi Conductive Compound
- Insulation: Cross-linked Polyethylene (XLPE) Compound
- Insulation Screen: Extruded Semi Conductive Compound
- Metallic Screen: Copper Tape Screen
- Assembled Core: PP Yarn Filler with Binder Tape
- Inner Sheath: Polyvinyl Chloride (PVC) Compound
- Armour: Double Steel Tape Armour (DSTA)
- Outer Sheath: Polyvinyl Chloride (PVC) Compound Type ST2
- Outer Sheath Colour: Black (other colours upon request)

ELECTRICAL CHARACTERISTICS

- Operating Voltage: 12.7/22KV
- Conductor Operating Temperature: 90°C
- Final Short Circuit Temperature: 250°C
- Test Voltage: 3.5U₀

AL/XLPE/CTS/PVC/DSTA/PVC (Three Core)

Nominal Area of Conductor (mm ²)	Nominal Diameter of Conductor (mm)	Approximate Weight of Conductor (kg/km)	Nominal Thickness of Insulation (mm)	Nominal Thickness of Inner Sheath (mm)	Nominal Thickness of Steel Tape (mm)	Nominal Thickness of Outer Sheath (mm)	Approximate Overall Diameter (mm)	Approximate Cable Weight (kg/km)
50	8.2	383	5.5	1.6	0.5	2.8	63	4,400
70	9.7	557	5.5	1.6	0.5	2.9	66	5,000
95	11.3	768	5.5	1.7	0.5	3.1	70	5,600
120	12.8	970	5.5	1.7	0.5	3.2	73	6,200
150	14.2	1,193	5.5	1.8	0.5	3.3	77	6,700
185	15.9	1,509	5.5	1.9	0.5	3.4	81	7,600
240	18.3	1,974	5.5	2.0	0.8	3.6	88	9,700
300	20.3	2,457	5.5	2.0	0.8	3.8	92	11,500
400	23.2	3,142	5.5	2.2	0.8	4.0	100	13,000

Table 24

AL-XCTDP AL/XLPE/CTS/PVC/DSTA/PVC (Three Core)

XLPE Insulated, PVC Bedded, Double Steel Tape Armoured, PVC Sheathed Cable
19/33KV (Max 36), IEC 60502-2

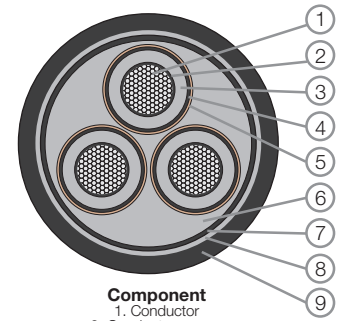
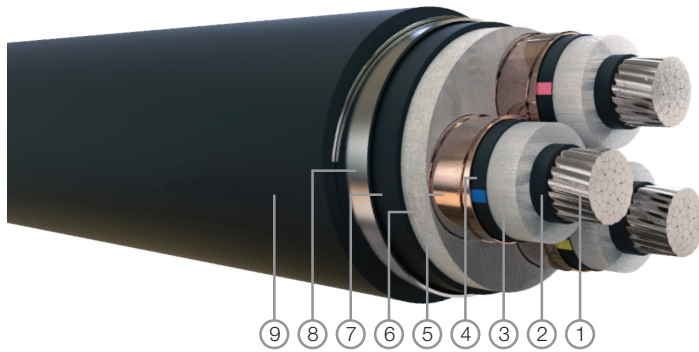

- Component**
1. Conductor
 2. Conductor screen
 3. Insulation
 4. Insulation screen
 5. Metallic screen (copper wire or copper tape)
 6. Filler & Binder Tape
 7. Inner sheath
 8. Armour
 9. Outer sheath

CONSTRUCTION

Conductor:	Plain Annealed Aluminium, Class 2 Conductor
Conductor Screen:	Extruded Semi Conductive Compound
Insulation:	Cross-linked Polyethylene (XLPE) Compound
Insulation Screen:	Extruded Semi Conductive Compound
Metallic Screen:	Copper Tape Screen
Assembled Core:	PP Yarn Filler with Binder Tape
Inner Sheath:	Polyvinyl Chloride (PVC) Compound
Armour:	Double Steel Tape Armour (DSTA)
Outer Sheath:	Polyvinyl Chloride (PVC) Compound Type ST2
Outer Sheath Colour:	Black (other colours upon request)

ELECTRICAL CHARACTERISTICS

Operating Voltage:	19/33KV
Conductor Operating Temperature:	90°C
Final Short Circuit Temperature:	250°C
Test Voltage:	3.5U ₀

AL/XLPE/CTS/PVC/DSTA/PVC (Three Core)

Nominal Area of Conductor (mm ²)	Nominal Diameter of Conductor (mm)	Approximate Weight of Conductor (kg/km)	Nominal Thickness of Insulation (mm)	Nominal Thickness of Inner Sheath (mm)	Nominal Thickness of Steel Tape (mm)	Nominal Thickness of Outer Sheath (mm)	Approximate Overall Diameter (mm)	Approximate Cable Weight (kg/km)
50	8.2	383	8.0	1.8	0.5	3.2	74	5,900
70	9.7	557	8.0	1.8	0.5	3.3	78	6,500
95	11.3	768	8.0	1.9	0.5	3.5	82	7,100
120	12.8	970	8.0	2.0	0.8	3.6	87	8,700
150	14.2	1,193	8.0	2.0	0.8	3.7	90	9,100
185	15.9	1,509	8.0	2.1	0.8	3.9	94	10,000
240	18.3	1,974	8.0	2.2	0.8	4.0	100	11,000
300	20.3	2,457	8.0	2.3	0.8	4.2	105	13,000
400	23.2	3,142	8.0	2.4	0.8	4.4	112	14,000

Table 25

AL-XCTSP AL/XLPE/CTS/PVC/SWA/PVC (Three Core)

XLPE Insulated, PVC Bedded, Steel Wire Armoured, PVC Sheathed Cable
3.8/6.6KV (Max 7.2), IEC 60502-2

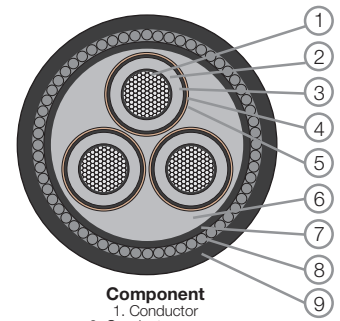
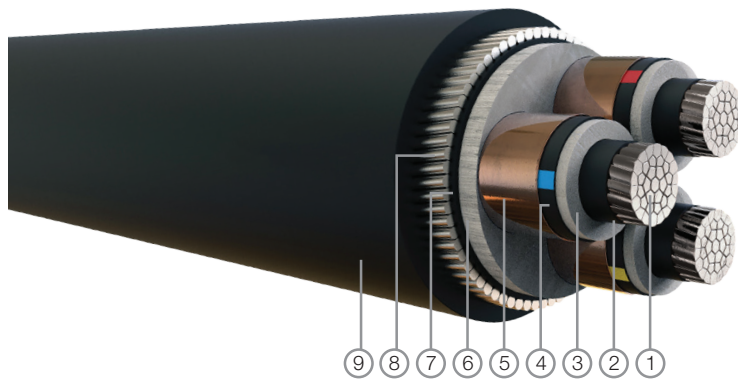

- Component**
1. Conductor
 2. Conductor screen
 3. Insulation
 4. Insulation screen
 5. Metallic screen (copper wire or copper tape)
 6. Filler & Binder Tape
 7. Inner sheath
 8. Armour
 9. Outer sheath

CONSTRUCTION

Conductor:	Plain Annealed Aluminium, Class 2 Conductor
Conductor Screen:	Extruded Semi Conductive Compound
Insulation:	Cross-linked Polyethylene (XLPE) Compound
Insulation Screen:	Extruded Semi Conductive Compound
Metallic Screen:	Copper Tape Screen
Assembled Core:	PP Yarn Filler with Binder Tape
Inner Sheath:	Polyvinyl Chloride (PVC) Compound
Armour:	Steel Wire Armour (SWA)
Outer Sheath:	Polyvinyl Chloride (PVC) Compound Type ST2
Outer Sheath Colour:	Black (other colours upon request)

ELECTRICAL CHARACTERISTICS

Operating Voltage:	3.8/6.6KV
Conductor Operating Temperature:	90°C
Final Short Circuit Temperature:	250°C
Test Voltage:	3.5U ₀

AL/XLPE/CTS/PVC/SWA/PVC (Three Core)

Nominal Area of Conductor (mm ²)	Nominal Diameter of Conductor (mm)	Approximate Weight of Conductor (kg/km)	Nominal Thickness of Insulation (mm)	Nominal Thickness of Inner Sheath (mm)	Nominal Armour Wire Diameter (mm)	Nominal Thickness of Outer Sheath (mm)	Approximate Overall Diameter (mm)	Approximate Cable Weight (kg/km)
50	8.2	383	2.5	1.3	2.5	2.5	52	4,400
70	9.7	557	2.5	1.4	2.5	2.6	56	5,000
95	11.3	768	2.5	1.4	2.5	2.7	60	5,700
120	12.8	970	2.5	1.5	2.5	2.8	64	6,300
150	14.2	1,193	2.5	1.5	2.5	2.9	67	7,000
185	15.9	1,509	2.5	1.6	2.5	3.0	71	7,900
240	18.3	1,974	2.6	1.7	2.5	3.2	77	9,200
300	20.3	2,457	2.8	1.8	3.15	3.5	84	12,000
400	23.2	3,142	3.0	2.0	3.15	3.8	93	14,000

Table 26

AL-XCTSP AL/XLPE/CTS/PVC/SWA/PVC (Three Core)

XLPE Insulated, PVC Bedded, Steel Wire Armoured, PVC Sheathed Cable
6.35/11KV (Max 12), IEC 60502-2

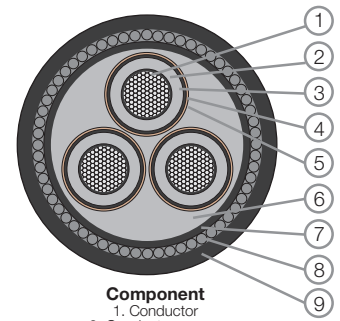
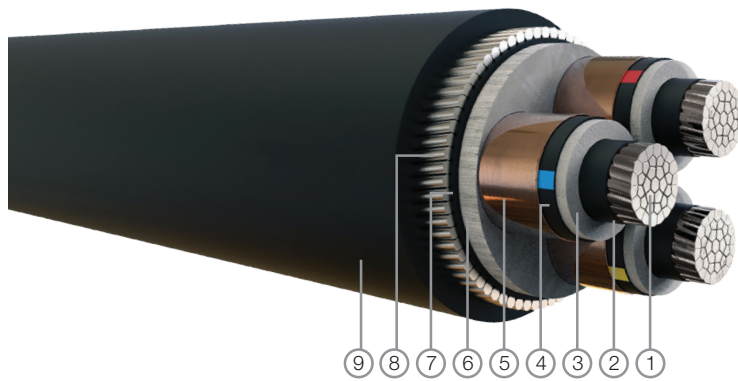

- Component**
1. Conductor
 2. Conductor screen
 3. Insulation
 4. Insulation screen
 5. Metallic screen (copper wire or copper tape)
 6. Filler & Binder Tape
 7. Inner sheath
 8. Armour
 9. Outer sheath

CONSTRUCTION

Conductor:	Plain Annealed Aluminium, Class 2 Conductor
Conductor Screen:	Extruded Semi Conductive Compound
Insulation:	Cross-linked Polyethylene (XLPE) Compound
Insulation Screen:	Extruded Semi Conductive Compound
Metallic Screen:	Copper Tape Screen
Assembled Core:	PP Yarn Filler with Binder Tape
Inner Sheath:	Polyvinyl Chloride (PVC) Compound
Armour:	Steel Wire Armour (SWA)
Outer Sheath:	Polyvinyl Chloride (PVC) Compound Type ST2
Outer Sheath Colour:	Black (other colours upon request)

ELECTRICAL CHARACTERISTICS

Operating Voltage:	6.35/11KV
Conductor Operating Temperature:	90°C
Final Short Circuit Temperature:	250°C
Test Voltage:	3.5U ₀

AL/XLPE/CTS/PVC/SWA/PVC (Three Core)

Nominal Area of Conductor (mm ²)	Nominal Diameter of Conductor (mm)	Approximate Weight of Conductor (kg/km)	Nominal Thickness of Insulation (mm)	Nominal Thickness of Inner Sheath (mm)	Nominal Armour Wire Diameter (mm)	Nominal Thickness of Outer Sheath (mm)	Approximate Overall Diameter (mm)	Approximate Cable Weight (kg/km)
50	8.2	383	3.4	1.4	2.5	2.6	56	5,000
70	9.7	557	3.4	1.4	2.5	2.7	60	5,600
95	11.3	768	3.4	1.5	2.5	2.9	64	6,300
120	12.8	970	3.4	1.6	2.5	3.0	68	6,900
150	14.2	1,193	3.4	1.6	2.5	3.1	71	7,600
185	15.9	1,509	3.4	1.7	2.5	3.2	75	8,600
240	18.3	1,974	3.4	1.8	3.15	3.4	82	10,700
300	20.3	2,457	3.4	1.9	3.15	3.5	87	12,800
400	23.2	3,142	3.4	2.0	3.15	3.8	95	14,600

Table 27

AL-XCTSP AL/XLPE/CTS/PVC/SWA/PVC (Three Core)

XLPE Insulated, PVC Bedded, Steel Wire Armoured, PVC Sheathed Cable
8.7/15KV (Max 17.5), IEC 60502-2

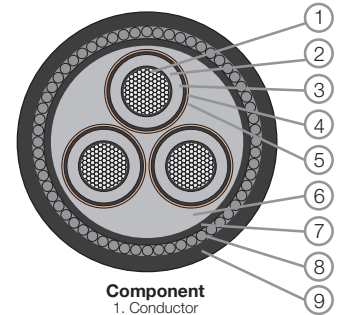
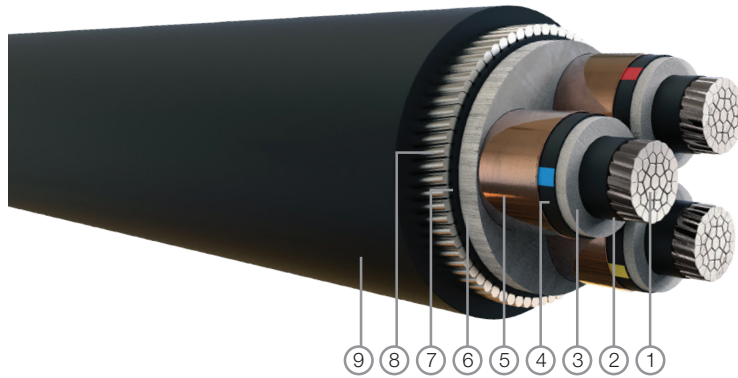

- Component**
1. Conductor
 2. Conductor screen
 3. Insulation
 4. Insulation screen
 5. Metallic screen (copper wire or copper tape)
 6. Filler & Binder Tape
 7. Inner sheath
 8. Armour
 9. Outer sheath

CONSTRUCTION

Conductor:	Plain Annealed Aluminium, Class 2 Conductor
Conductor Screen:	Extruded Semi Conductive Compound
Insulation:	Cross-linked Polyethylene (XLPE) Compound
Insulation Screen:	Extruded Semi Conductive Compound
Metallic Screen:	Copper Tape Screen
Assembled Core:	PP Yarn Filler with Binder Tape
Inner Sheath:	Polyvinyl Chloride (PVC) Compound
Armour:	Steel Wire Armour (SWA)
Outer Sheath:	Polyvinyl Chloride (PVC) Compound Type ST2
Outer Sheath Colour:	Black (other colours upon request)

ELECTRICAL CHARACTERISTICS

Operating Voltage:	8.7/15KV
Conductor Operating Temperature:	90°C
Final Short Circuit Temperature:	250°C
Test Voltage:	3.5U ₀

AL/XLPE/CTS/PVC/SWA/PVC (Three Core)

Nominal Area of Conductor (mm ²)	Nominal Diameter of Conductor (mm)	Approximate Weight of Conductor (kg/km)	Nominal Thickness of Insulation (mm)	Nominal Thickness of Inner Sheath (mm)	Nominal Armour Wire Diameter (mm)	Nominal Thickness of Outer Sheath (mm)	Approximate Overall Diameter (mm)	Approximate Cable Weight (kg/km)
50	8.2	383	4.5	1.5	2.5	2.8	62	5,800
70	9.7	557	4.5	1.5	2.5	2.9	66	6,400
95	11.3	768	4.5	1.6	2.5	3.0	70	7,300
120	12.8	970	4.5	1.7	2.5	3.1	73	8,000
150	14.2	1,193	4.5	1.7	2.5	3.2	77	8,700
185	15.9	1,509	4.5	1.8	3.15	3.4	82	10,500
240	18.3	1,974	4.5	1.9	3.15	3.6	88	11,900
300	20.3	2,457	4.5	2.0	3.15	3.7	93	14,200
400	23.2	3,142	4.5	2.1	3.15	4.0	99	16,000

Table 28

AL-XCTSP AL/XLPE/CTS/PVC/SWA/PVC (Three Core)

XLPE Insulated, PVC Bedded, Steel Wire Armoured, PVC Sheathed Cable
12.7/22KV (Max 24), IEC 60502-2

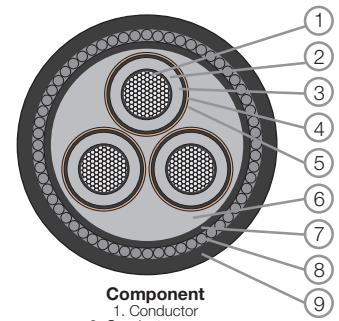
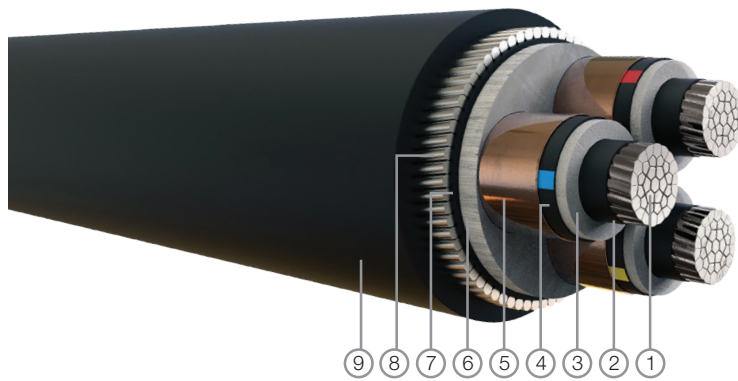

- Component**
1. Conductor
 2. Conductor screen
 3. Insulation
 4. Insulation screen
 5. Metallic screen (copper wire or copper tape)
 6. Filler & Binder Tape
 7. Inner sheath
 8. Armour
 9. Outer sheath

CONSTRUCTION

Conductor:	Plain Annealed Aluminium, Class 2 Conductor
Conductor Screen:	Extruded Semi Conductive Compound
Insulation:	Cross-linked Polyethylene (XLPE) Compound
Insulation Screen:	Extruded Semi Conductive Compound
Metallic Screen:	Copper Tape Screen
Assembled Core:	PP Yarn Filler with Binder Tape
Inner Sheath:	Polyvinyl Chloride (PVC) Compound
Armour:	Steel Wire Armour (SWA)
Outer Sheath:	Polyvinyl Chloride (PVC) Compound Type ST2
Outer Sheath Colour:	Black (other colours upon request)

ELECTRICAL CHARACTERISTICS

Operating Voltage:	12.7/22KV
Conductor Operating Temperature:	90°C
Final Short Circuit Temperature:	250°C
Test Voltage:	3.5U ₀

AL/XLPE/CTS/PVC/SWA/PVC (Three Core)

Nominal Area of Conductor (mm ²)	Nominal Diameter of Conductor (mm)	Approximate Weight of Conductor (kg/km)	Nominal Thickness of Insulation (mm)	Nominal Thickness of Inner Sheath (mm)	Nominal Armour Wire Diameter (mm)	Nominal Thickness of Outer Sheath (mm)	Approximate Overall Diameter (mm)	Approximate Cable Weight (kg/km)
50	8.2	383	5.5	1.6	2.5	2.9	67	6,200
70	9.7	557	5.5	1.6	2.5	3.1	71	6,700
95	11.3	768	5.5	1.7	2.5	3.2	75	7,700
120	12.8	970	5.5	1.7	3.15	3.3	79	9,300
150	14.2	1,193	5.5	1.8	3.15	3.4	83	10,100
185	15.9	1,509	5.5	1.9	3.15	3.6	87	11,100
240	18.3	1,974	5.5	2.0	3.15	3.7	93	12,500
300	20.3	2,457	5.5	2.0	3.15	3.9	97	14,700
400	23.2	3,142	5.5	2.2	3.15	4.1	105	16,600

Table 29

AL-XCTSP AL/XLPE/CTS/PVC/SWA/PVC (Three Core)

XLPE Insulated, PVC Bedded, Steel Wire Armoured, PVC Sheathed Cable
19/33KV (Max 36), IEC 60502-2

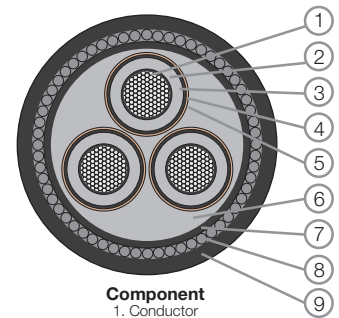
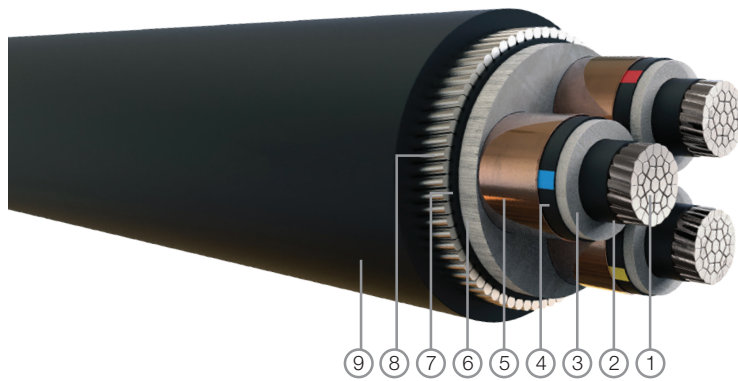

- Component**
1. Conductor
 2. Conductor screen
 3. Insulation
 4. Insulation screen
 5. Metallic screen (copper wire or copper tape)
 6. Filler & Binder Tape
 7. Inner sheath
 8. Armour
 9. Outer sheath

CONSTRUCTION

Conductor:	Plain Annealed Aluminium, Class 2 Conductor
Conductor Screen:	Extruded Semi Conductive Compound
Insulation:	Cross-linked Polyethylene (XLPE) Compound
Insulation Screen:	Extruded Semi Conductive Compound
Metallic Screen:	Copper Tape Screen
Assembled Core:	PP Yarn Filler with Binder Tape
Inner Sheath:	Polyvinyl Chloride (PVC) Compound
Armour:	Steel Wire Armour (SWA)
Outer Sheath:	Polyvinyl Chloride (PVC) Compound Type ST2
Outer Sheath Colour:	Black (other colours upon request)

ELECTRICAL CHARACTERISTICS

Operating Voltage:	19/33KV
Conductor Operating Temperature:	90°C
Final Short Circuit Temperature:	250°C
Test Voltage:	3.5U ₀

AL/XLPE/CTS/PVC/SWA/PVC (Three Core)

Nominal Area of Conductor (mm ²)	Nominal Diameter of Conductor (mm)	Approximate Weight of Conductor (kg/km)	Nominal Thickness of Insulation (mm)	Nominal Thickness of Inner Sheath (mm)	Nominal Armour Wire Diameter (mm)	Nominal Thickness of Outer Sheath (mm)	Approximate Overall Diameter (mm)	Approximate Cable Weight (kg/km)
50	8.2	383	8.0	1.8	3.15	3.4	80	9,000
70	9.7	557	8.0	1.8	3.15	3.5	84	9,400
95	11.3	768	8.0	1.9	3.15	3.6	88	9,700
120	12.8	970	8.0	2.0	3.15	3.7	92	11,600
150	14.2	1,193	8.0	2.0	3.15	3.8	95	12,100
185	15.9	1,509	8.0	2.1	3.15	4.0	99	13,500
240	18.3	1,974	8.0	2.2	3.15	4.1	105	14,400
300	20.3	2,457	8.0	2.3	3.15	4.3	110	17,200
400	23.2	3,142	8.0	2.4	3.15	4.5	116	18,600

Table 30

FRT-AL-XCTH AL/XLPE/CTS/LSZH (Single Core)

XLPE Insulated, LSZH Sheathed Cable 3.8/6.6KV (Max 7.2), IEC 60502-2

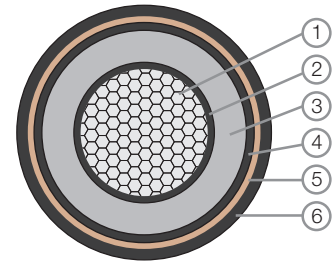
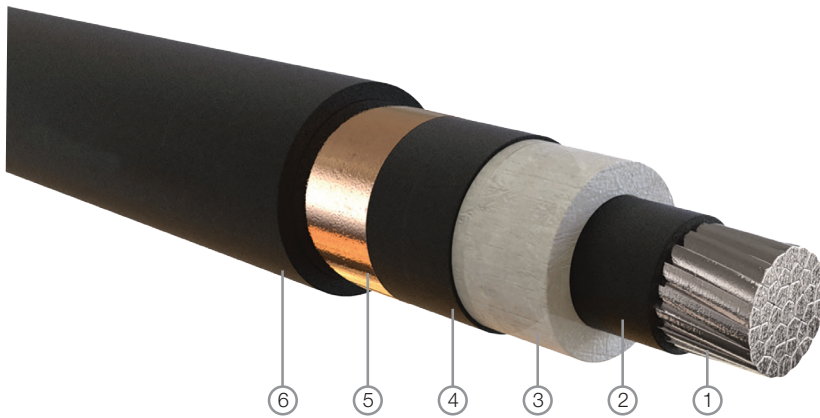

- Component**
1. Conductor
 2. Conductor screen
 3. Insulation
 4. Insulation screen
 5. Metallic screen (copper wire or copper tape)
 6. Outer sheath

CONSTRUCTION

Conductor:	Plain Annealed Aluminium, Class 2 Conductor
Conductor Screen:	Extruded Semi Conductive Compound
Insulation:	Cross-linked Polyethylene (XLPE) Compound
Insulation Screen:	Extruded semi conductive compound
Metallic Screen:	Copper Tape Screen
Outer Sheath:	LSZH Flame Retardant Polyolefin
Outer Sheath Colour:	Black (other colours upon request)

ELECTRICAL CHARACTERISTICS

Operating Voltage:	3.8/6.6KV
Conductor Operating Temperature:	90°C
Final Short Circuit Temperature:	250°C
Test Voltage:	3.5U ₀

AL/XLPE/CTS/LSZH (Single Core)

Nominal Area of Conductor (mm ²)	Nominal Diameter of Conductor (mm)	Approximate Weight of Conductor (kg/km)	Nominal Thickness of Insulation (mm)	Nominal Thickness of Outer Sheath (mm)	Approximate Overall Diameter (mm)	Approximate Cable Weight (kg/km)
70	9.7	182	2.5	1.8	23	640
95	11.3	251	2.5	1.8	24	770
120	12.8	317	2.5	1.8	26	900
150	14.2	390	2.5	1.8	27	960
185	15.9	493	2.5	1.8	29	1,090
240	18.3	645	2.6	1.9	32	1,340
300	20.3	803	2.8	2.0	35	1,560
400	23.2	1,027	3.0	2.1	38	2,040
500	26.2	1,305	3.2	2.2	41	2,400
630	30.0	1,720	3.2	2.3	46	2,900
800	34.0	2,200	3.2	2.4	50	3,500
1,000	38.2	2,750	3.2	2.6	55	4,300
1,200	43.0	3,290	3.2	2.8	60	5,000

Table 31

FRT-AL-XCTH AL/XLPE/CTS/LSZH (Single Core)

XLPE Insulated, LSZH Sheathed Cable 6.5/11KV (Max 12), IEC 60502-2

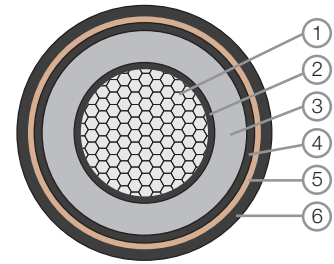
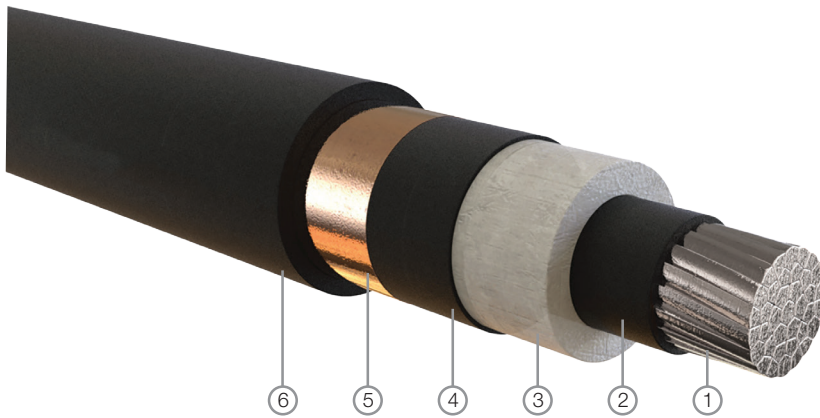

- Component**
1. Conductor
 2. Conductor screen
 3. Insulation
 4. Insulation screen
 5. Metallic screen (copper wire or copper tape)
 6. Outer sheath

CONSTRUCTION

Conductor:	Plain Annealed Aluminium, Class 2 Conductor
Conductor Screen:	Extruded Semi Conductive Compound
Insulation:	Cross-linked Polyethylene (XLPE) Compound
Insulation Screen:	Extruded semi conductive compound
Metallic Screen:	Copper Tape Screen
Outer Sheath:	LSZH Flame Retardant Polyolefin
Outer Sheath Colour:	Black (other colours upon request)

ELECTRICAL CHARACTERISTICS

Operating Voltage:	6.35/11KV
Conductor Operating Temperature:	90°C
Final Short Circuit Temperature:	250°C
Test Voltage:	3.5U ₀

AL/XLPE/CTS/LSZH (Single Core)

Nominal Area of Conductor (mm ²)	Nominal Diameter of Conductor (mm)	Approximate Weight of Conductor (kg/km)	Nominal Thickness of Insulation (mm)	Nominal Thickness of Outer Sheath (mm)	Approximate Overall Diameter (mm)	Approximate Cable Weight (kg/km)
70	9.7	182	3.4	1.8	25	680
95	11.3	251	3.4	1.8	27	800
120	12.8	317	3.4	1.8	28	930
150	14.2	390	3.4	1.8	30	1,010
185	15.9	493	3.4	1.9	32	1,190
240	18.3	645	3.4	2.0	34	1,440
300	20.3	803	3.4	2.0	36	1,660
400	23.2	1,027	3.4	2.1	39	2,100
500	26.2	1,305	3.4	2.2	44	2,500
630	30.0	1,720	3.4	2.3	47	3,100
800	34.0	2,200	3.4	2.5	51	3,600
1,000	38.2	2,750	3.4	2.6	55	4,400
1,200	43.0	3,290	3.4	2.8	61	5,100

Table 32

FRT-AL-XCTH AL/XLPE/CTS/LSZH (Single Core)

XLPE Insulated, LSZH Sheathed Cable 8.7/15KV (Max 17.5), IEC 60502-2

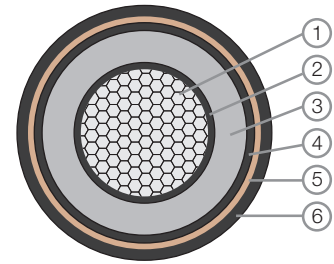
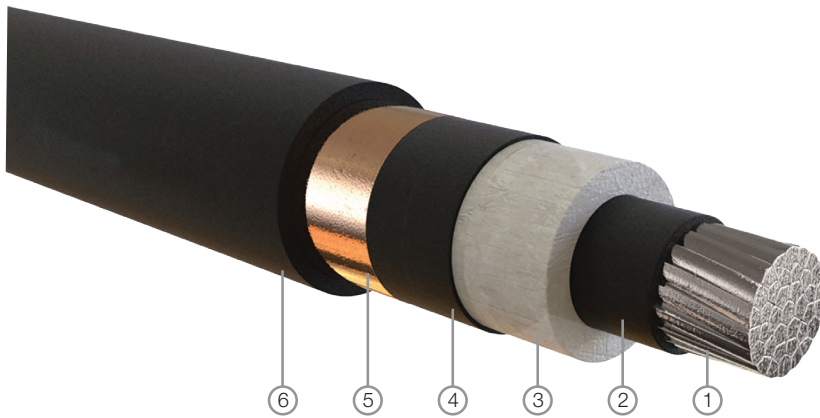

- Component**
1. Conductor
 2. Conductor screen
 3. Insulation
 4. Insulation screen
 5. Metallic screen (copper wire or copper tape)
 6. Outer sheath

CONSTRUCTION

Conductor:	Plain Annealed Aluminium, Class 2 Conductor
Conductor Screen:	Extruded Semi Conductive Compound
Insulation:	Cross-linked Polyethylene (XLPE) Compound
Insulation Screen:	Extruded semi conductive compound
Metallic Screen:	Copper Tape Screen
Outer Sheath:	LSZH Flame Retardant Polyolefin
Outer Sheath Colour:	Black (other colours upon request)

ELECTRICAL CHARACTERISTICS

Operating Voltage:	8.7/15KV
Conductor Operating Temperature:	90°C
Final Short Circuit Temperature:	250°C
Test Voltage:	3.5U ₀

AL/XLPE/CTS/LSZH (Single Core)

Nominal Area of Conductor (mm ²)	Nominal Diameter of Conductor (mm)	Approximate Weight of Conductor (kg/km)	Nominal Thickness of Insulation (mm)	Nominal Thickness of Outer Sheath (mm)	Approximate Overall Diameter (mm)	Approximate Cable Weight (kg/km)
70	9.7	182	4.5	1.8	27	790
95	11.3	251	4.5	1.8	29	920
120	12.8	317	4.5	1.9	31	1,030
150	14.2	390	4.5	1.9	32	1,200
185	15.9	493	4.5	2.0	34	1,350
240	18.3	645	4.5	2.0	36	1,550
300	20.3	803	4.5	2.1	39	1,800
400	23.2	1,027	4.5	2.2	42	2,200
500	26.2	1,305	4.5	2.3	45	2,600
630	30.0	1,720	4.5	2.4	49	3,300
800	34.0	2,200	4.5	2.5	53	3,800
1,000	38.2	2,750	4.5	2.7	58	4,600
1,200	43.0	3,290	4.5	2.9	64	5,400

Table 33

FRT-AL-XCTH AL/XLPE/CTS/LSZH (Single Core)

XLPE Insulated, LSZH Sheathed Cable 12.7/22KV (Max 24), IEC 60502-2

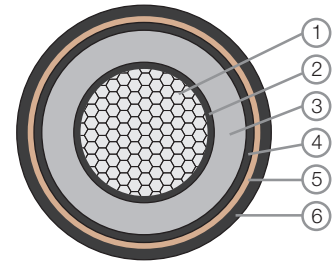
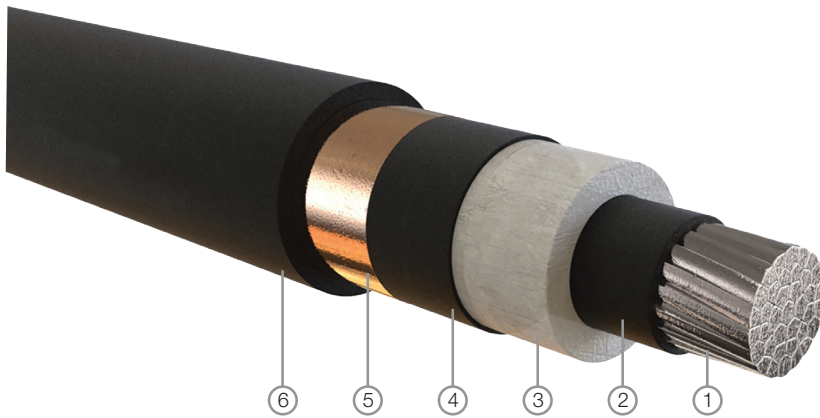

- Component**
1. Conductor
 2. Conductor screen
 3. Insulation
 4. Insulation screen
 5. Metallic screen (copper wire or copper tape)
 6. Outer sheath

CONSTRUCTION

Conductor:	Plain Annealed Aluminium, Class 2 Conductor
Conductor Screen:	Extruded Semi Conductive Compound
Insulation:	Cross-linked Polyethylene (XLPE) Compound
Insulation Screen:	Extruded semi conductive compound
Metallic Screen:	Copper Tape Screen
Outer Sheath:	LSZH Flame Retardant Polyolefin
Outer Sheath Colour:	Black (other colours upon request)

ELECTRICAL CHARACTERISTICS

Operating Voltage:	12.7/22KV
Conductor Operating Temperature:	90°C
Final Short Circuit Temperature:	250°C
Test Voltage:	3.5U ₀

AL/XLPE/CTS/LSZH (Single Core)

Nominal Area of Conductor (mm ²)	Nominal Diameter of Conductor (mm)	Approximate Weight of Conductor (kg/km)	Nominal Thickness of Insulation (mm)	Nominal Thickness of Outer Sheath (mm)	Approximate Overall Diameter (mm)	Approximate Cable Weight (kg/km)
70	9.7	182	5.5	1.8	29	890
95	11.3	251	5.5	1.9	31	1,030
120	12.8	317	5.5	1.9	33	1,180
150	14.2	390	5.5	2.0	34	1,400
185	15.9	493	5.5	2.0	35	1,590
240	18.3	645	5.5	2.1	38	1,800
300	20.3	803	5.5	2.2	41	2,000
400	23.2	1,027	5.5	2.3	44	2,500
500	26.2	1,305	5.5	2.4	47	2,900
630	30.0	1,720	5.5	2.5	51	3,500
800	34.0	2,200	5.5	2.6	56	4,050
1,000	38.2	2,750	5.5	2.7	60	4,900
1,200	43.0	3,290	5.5	2.9	66	5,530

Table 34

FRT-AL-XCTH AL/XLPE/CTS/LSZH (Single Core)

XLPE Insulated, LSZH Sheathed Cable 19/33KV (Max 36), IEC 60502-2

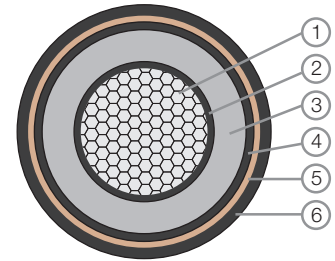
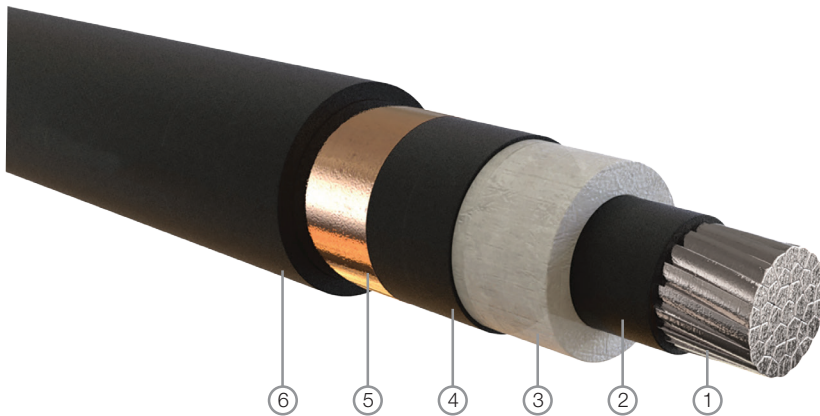

- Component**
1. Conductor
 2. Conductor screen
 3. Insulation
 4. Insulation screen
 5. Metallic screen (copper wire or copper tape)
 6. Outer sheath

CONSTRUCTION

Conductor:	Plain Annealed Aluminium, Class 2 Conductor
Conductor Screen:	Extruded Semi Conductive Compound
Insulation:	Cross-linked Polyethylene (XLPE) Compound
Insulation Screen:	Extruded semi conductive compound
Metallic Screen:	Copper Tape Screen
Outer Sheath:	LSZH Flame Retardant Polyolefin
Outer Sheath Colour:	Black (other colours upon request)

ELECTRICAL CHARACTERISTICS

Operating Voltage:	19/33KV
Conductor Operating Temperature:	90°C
Final Short Circuit Temperature:	250°C
Test Voltage:	3.5U ₀

AL/XLPE/CTS/LSZH (Single Core)

Nominal Area of Conductor (mm ²)	Nominal Diameter of Conductor (mm)	Approximate Weight of Conductor (kg/km)	Nominal Thickness of Insulation (mm)	Nominal Thickness of Outer Sheath (mm)	Approximate Overall Diameter (mm)	Approximate Cable Weight (kg/km)
70	9.7	182	8.0	2.0	35	1,200
95	11.3	251	8.0	2.1	37	1,400
120	12.8	317	8.0	2.1	38	1,500
150	14.2	390	8.0	2.1	40	1,600
185	15.9	493	8.0	2.2	42	1,800
240	18.3	645	8.0	2.3	44	2,100
300	20.3	803	8.0	2.3	46	2,500
400	23.2	1,027	8.0	2.5	50	2,800
500	26.2	1,305	8.0	2.5	53	3,500
630	30.0	1,720	8.0	2.7	57	4,000
800	34.0	2,200	8.0	2.8	61	4,600
1,000	38.2	2,750	8.0	2.9	66	5,500
1,200	43.0	3,290	8.0	3.0	71	6,800

Table 35

FRT-AL-XCTH AL/XLPE/CTS/LSZH (Three Core)

XLPE Insulated, LSZH Sheathed Cable 3.8/6.6KV (Max 7.2), IEC 60502-2

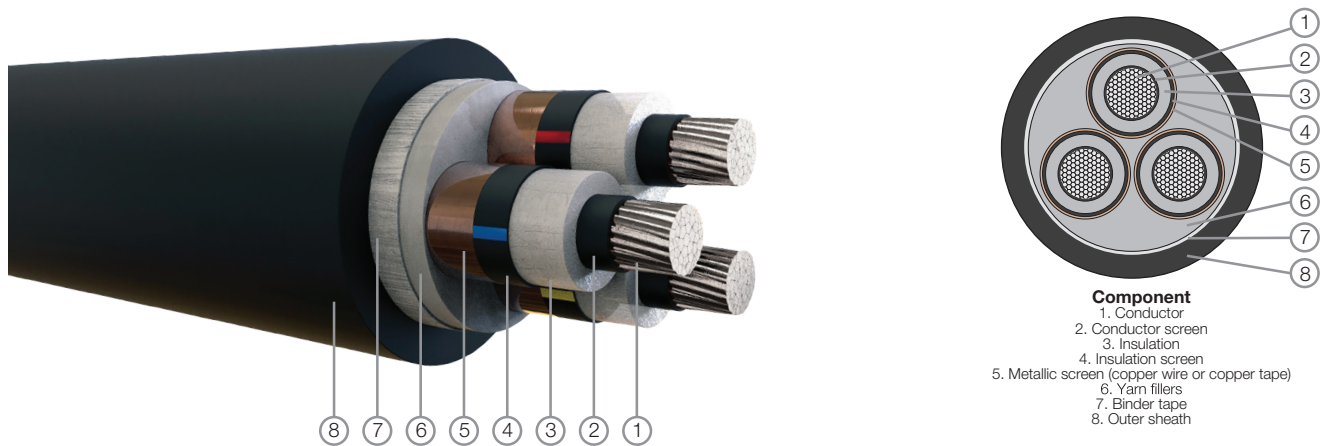

CONSTRUCTION

Conductor:	Plain Annealed Aluminium, Class 2 Conductor
Conductor Screen	Extruded Semi Conductive Compound
Insulation:	Cross-linked Polyethylene (XLPE) Compound
Insulation Screen:	Extruded Semi Conductive Compound
Metallic Screen:	Copper Tape Screen
Assembled Core:	PP Yarn Filler with Binder Tape
Outer Sheath:	LSZH Flame Retardant Polyolefin
Outer Sheath Colour:	Black (other colours upon request)

ELECTRICAL CHARACTERISTICS

Operating Voltage:	3.8/6.6KV
Conductor Operating Temperature:	90°C
Final Short Circuit Temperature:	250°C
Test Voltage:	3.5U ₀

AL/XLPE/CTS/LSZH (Three Core)

Nominal Area of Conductor (mm ²)	Nominal Diameter of Conductor (mm)	Approximate Weight of Conductor (kg/km)	Nominal Thickness of Insulation (mm)	Nominal Thickness of Outer Sheath (mm)	Approximate Overall Diameter (mm)	Approximate Cable Weight (kg/km)
50	8.2	383	2.5	2.2	44	1,900
70	9.7	557	2.5	2.3	47	2,200
95	11.3	768	2.5	2.5	51	2,600
120	12.8	970	2.5	2.6	54	3,100
150	14.2	1,193	2.5	2.7	57	3,500
185	15.9	1,509	2.5	2.8	61	3,900
240	18.3	1,974	2.6	3.0	67	4,800
300	20.3	2,457	2.8	3.2	73	5,500
400	23.2	3,142	3.0	3.4	81	7,500

Table 36

FRT-AL-XCTH AL/XLPE/CTS/LSZH (Three Core)

XLPE Insulated, LSZH Sheathed Cable 6.35/11KV (Max 12), IEC 60502-2

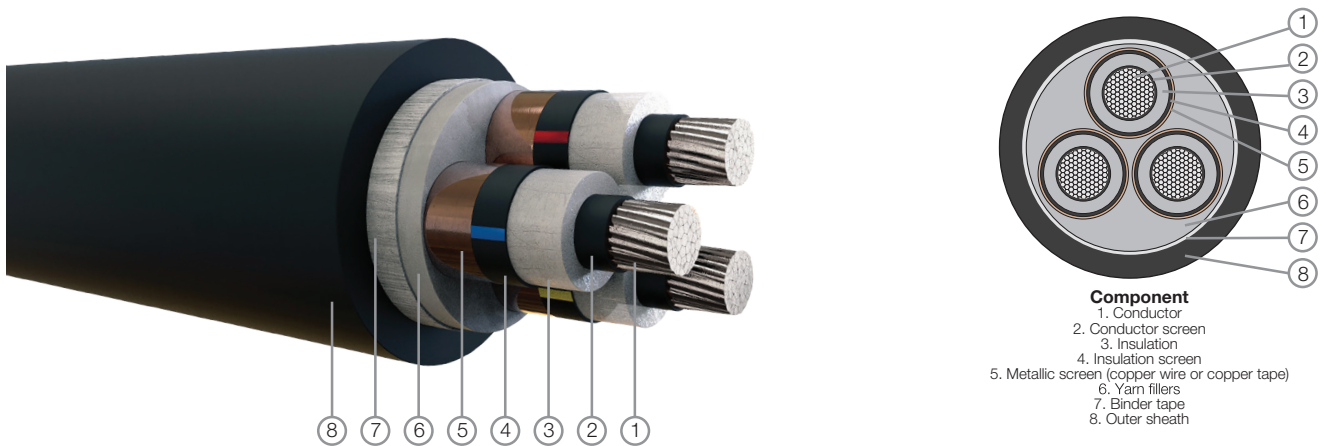

CONSTRUCTION

Conductor:	Plain Annealed Aluminium, Class 2 Conductor
Conductor Screen	Extruded Semi Conductive Compound
Insulation:	Cross-linked Polyethylene (XLPE) Compound
Insulation Screen:	Extruded Semi Conductive Compound
Metallic Screen:	Copper Tape Screen
Assembled Core:	PP Yarn Filler with Binder Tape
Outer Sheath:	LSZH Flame Retardant Polyolefin
Outer Sheath Colour:	Black (other colours upon request)

ELECTRICAL CHARACTERISTICS

Operating Voltage:	6.35/11KV
Conductor Operating Temperature:	90°C
Final Short Circuit Temperature:	250°C
Test Voltage:	3.5U ₀

AL/XLPE/CTS/LSZH (Three Core)

Nominal Area of Conductor (mm ²)	Nominal Diameter of Conductor (mm)	Approximate Weight of Conductor (kg/km)	Nominal Thickness of Insulation (mm)	Nominal Thickness of Outer Sheath (mm)	Approximate Overall Diameter (mm)	Approximate Cable Weight (kg/km)
50	8.2	383	3.4	2.4	48	2,100
70	9.7	557	3.4	2.5	51	2,500
95	11.3	768	3.4	2.6	55	2,700
120	12.8	970	3.4	2.7	58	3,400
150	14.2	1,193	3.4	2.8	62	3,700
185	15.9	1,509	3.4	2.9	66	4,400
240	18.3	1,974	3.4	3.1	71	5,200
300	20.3	2,457	3.4	3.3	76	6,300
400	23.2	3,142	3.4	3.5	83	7,800

Table 37

FRT-AL-XCTH AL/XLPE/CTS/LSZH (Three Core)

XLPE Insulated, LSZH Sheathed Cable 8.7/15KV (Max 17.5), IEC 60502-2

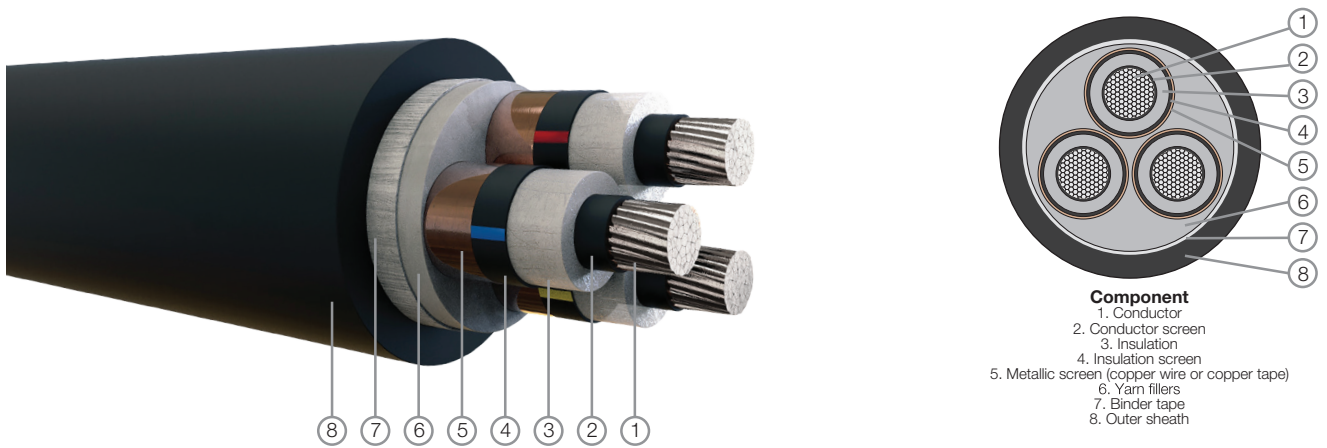

CONSTRUCTION

Conductor:	Plain Annealed Aluminium, Class 2 Conductor
Conductor Screen	Extruded Semi Conductive Compound
Insulation:	Cross-linked Polyethylene (XLPE) Compound
Insulation Screen:	Extruded Semi Conductive Compound
Metallic Screen:	Copper Tape Screen
Assembled Core:	PP Yarn Filler with Binder Tape
Outer Sheath:	LSZH Flame Retardant Polyolefin
Outer Sheath Colour:	Black (other colours upon request)

ELECTRICAL CHARACTERISTICS

Operating Voltage:	8.7/15KV
Conductor Operating Temperature:	90°C
Final Short Circuit Temperature:	250°C
Test Voltage:	3.5U ₀

AL/XLPE/CTS/LSZH (Three Core)

Nominal Area of Conductor (mm ²)	Nominal Diameter of Conductor (mm)	Approximate Weight of Conductor (kg/km)	Nominal Thickness of Insulation (mm)	Nominal Thickness of Outer Sheath (mm)	Approximate Overall Diameter (mm)	Approximate Cable Weight (kg/km)
50	8.2	383	4.5	2.6	53	2,600
70	9.7	557	4.5	2.7	57	2,900
95	11.3	768	4.5	2.8	60	3,400
120	12.8	970	4.5	2.9	64	5,200
150	14.2	1,193	4.5	3.0	67	4,400
185	15.9	1,509	4.5	3.1	71	4,900
240	18.3	1,974	4.5	3.3	76	5,600
300	20.3	2,457	4.5	3.4	81	6,800
400	23.2	3,142	4.5	3.7	87	8,200

Table 38

FRT-AL-XCTH AL/XLPE/CTS/LSZH (Three Core)

XLPE Insulated, LSZH Sheathed Cable 12.7/22KV (Max 24), IEC 60502-2

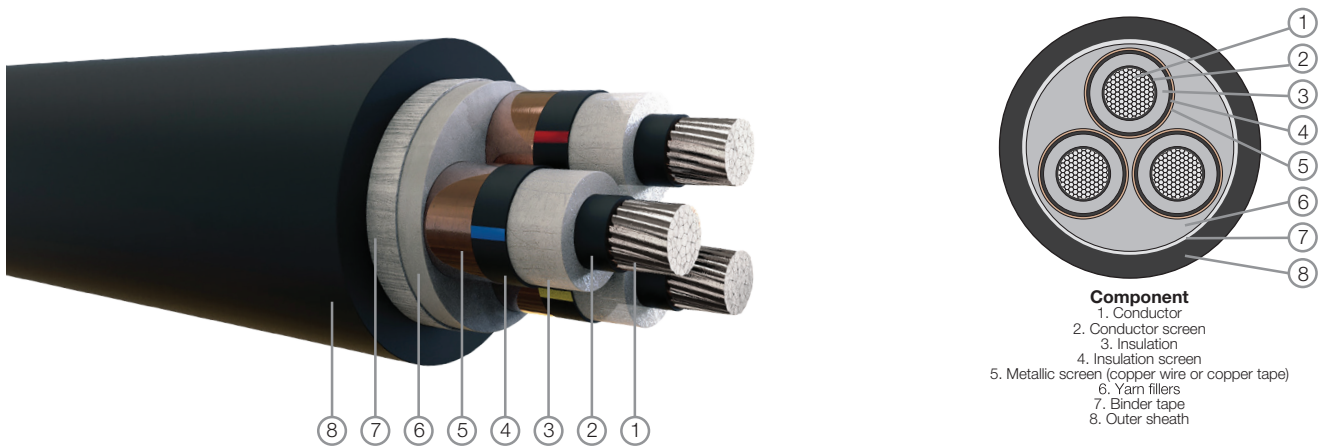

CONSTRUCTION

Conductor:	Plain Annealed Aluminium, Class 2 Conductor
Conductor Screen	Extruded Semi Conductive Compound
Insulation:	Cross-linked Polyethylene (XLPE) Compound
Insulation Screen:	Extruded Semi Conductive Compound
Metallic Screen:	Copper Tape Screen
Assembled Core:	PP Yarn Filler with Binder Tape
Outer Sheath:	LSZH Flame Retardant Polyolefin
Outer Sheath Colour:	Black (other colours upon request)

ELECTRICAL CHARACTERISTICS

Operating Voltage:	12.7/22KV
Conductor Operating Temperature:	90°C
Final Short Circuit Temperature:	250°C
Test Voltage:	3.5U ₀

AL/XLPE/CTS/LSZH (Three Core)

Nominal Area of Conductor (mm ²)	Nominal Diameter of Conductor (mm)	Approximate Weight of Conductor (kg/km)	Nominal Thickness of Insulation (mm)	Nominal Thickness of Outer Sheath (mm)	Approximate Overall Diameter (mm)	Approximate Cable Weight (kg/km)
50	8.2	383	5.5	2.7	57	3,000
70	9.7	557	5.5	2.8	61	3,300
95	11.3	768	5.5	2.9	65	3,700
120	12.8	970	5.5	3.0	68	4,200
150	14.2	1,193	5.5	3.1	72	4,800
185	15.9	1,509	5.5	3.3	76	5,600
240	18.3	1,974	5.5	3.4	81	6,500
300	20.3	2,457	5.5	3.6	90	7,800
400	23.2	3,142	5.5	3.8	96	8,700

Table 39

FRT-AL-XCTH AL/XLPE/CTS/LSZH (Three Core)

XLPE Insulated, LSZH Sheathed Cable 19/33KV (Max 36), IEC 60502-2

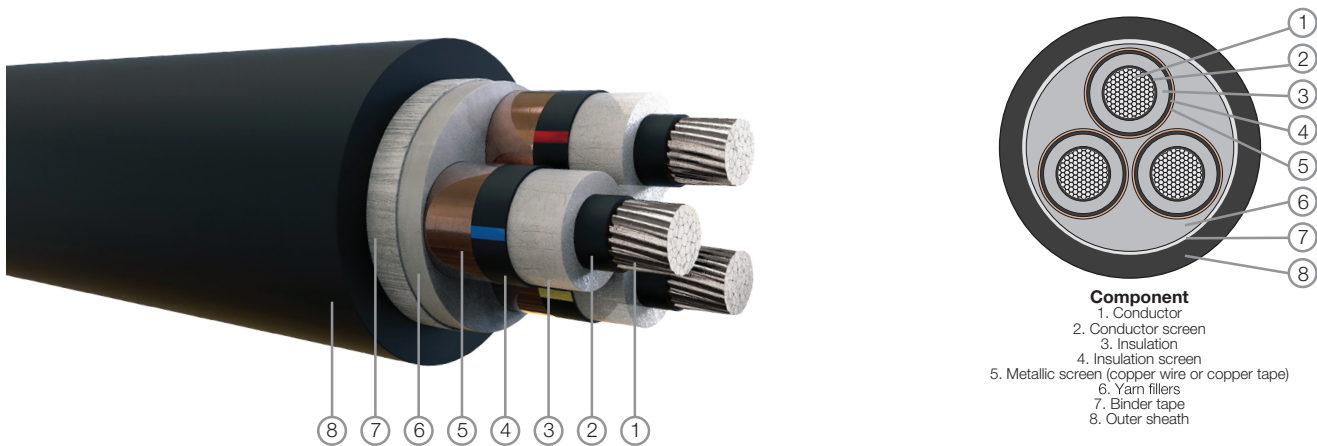

CONSTRUCTION

Conductor:	Plain Annealed Aluminium, Class 2 Conductor
Conductor Screen	Extruded Semi Conductive Compound
Insulation:	Cross-linked Polyethylene (XLPE) Compound
Insulation Screen:	Extruded Semi Conductive Compound
Metallic Screen:	Copper Tape Screen
Assembled Core:	PP Yarn Filler with Binder Tape
Outer Sheath:	LSZH Flame Retardant Polyolefin
Outer Sheath Colour:	Black (other colours upon request)

ELECTRICAL CHARACTERISTICS

Operating Voltage:	19/33KV
Conductor Operating Temperature:	90°C
Final Short Circuit Temperature:	250°C
Test Voltage:	3.5U ₀

AL/XLPE/CTS/LSZH (Three Core)

Nominal Area of Conductor (mm ²)	Nominal Diameter of Conductor (mm)	Approximate Weight of Conductor (kg/km)	Nominal Thickness of Insulation (mm)	Nominal Thickness of Outer Sheath (mm)	Approximate Overall Diameter (mm)	Approximate Cable Weight (kg/km)
50	8.2	383	8.0	3.1	69	5,100
70	9.7	557	8.0	3.2	73	6,000
95	11.3	768	8.0	3.3	77	7,000
120	12.8	970	8.0	3.4	80	8,000
150	14.2	1,193	8.0	3.5	83	9,100
185	15.9	1,509	8.0	3.6	87	10,500
240	18.3	1,974	8.0	3.8	93	12,500
300	20.3	2,457	8.0	4.0	101	15,500
400	23.2	3,142	8.0	4.2	108	18,300

Table 40

FRT-AL-XCTAH AL/XLPE/CTS/LSZH/AWA/LSZH (Single Core)

XLPE Insulated, LSZH Bedded, Aluminium Wire Armoured, LSZH Sheathed Cable
3.8/6.6KV (Max 7.2), IEC 60502-2

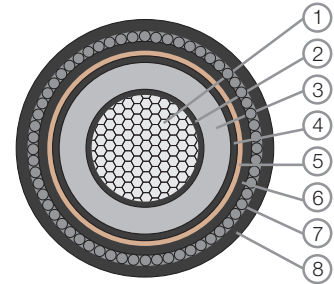
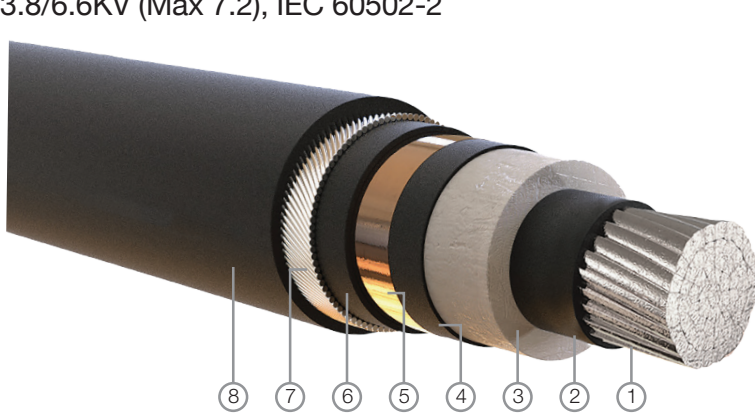

- Component**
1. Conductor
 2. Conductor screen
 3. Insulation
 4. Insulation screen
 5. Metallic screen (copper wire or copper tape)
 6. Inner sheath
 7. Armour
 8. Outer sheath

CONSTRUCTION

Conductor:	Plain Annealed Aluminium, Class 2 Conductor
Conductor Screen:	Extruded Semi Conductive Compound
Insulation:	Cross-linked Polyethylene (XLPE) Compound
Insulation Screen:	Extruded Semi Conductive Compound
Metallic Screen:	Copper Tape Screen
Inner Sheath:	LSZH Flame Retardant Polyolefin
Armour:	Aluminium Wire Armour (AWA) (DATA upon request)
Outer Sheath:	LSZH Flame Retardant Polyolefin
Outer Sheath Colour:	Black (other colours upon request)

ELECTRICAL CHARACTERISTICS

Operating Voltage:	3.8/6.6KV
Conductor Operating Temperature:	90°C
Final Short Circuit Temperature:	250°C
Test Voltage:	3.5U ₀

AL/XLPE/CTS/LSZH/AWA/LSZH (Single Core)

Nominal Area of Conductor (mm ²)	Nominal Diameter of Conductor (mm)	Approximate Weight of Conductor (kg/km)	Nominal Thickness of Insulation (mm)	Nominal Thickness of Inner Sheath (mm)	Nominal Armour Wire Diameter (mm)	Nominal Thickness of Outer Sheath (mm)	Approximate Overall Diameter (mm)	Approximate Cable Weight (kg/km)
70	9.7	182	2.5	1.2	1.6	1.8	31	1,100
95	11.3	251	2.5	1.2	1.6	1.9	33	1,200
120	12.8	317	2.5	1.2	1.6	1.9	34	1,300
150	14.2	390	2.5	1.2	1.6	2.0	36	1,500
185	15.9	493	2.5	1.2	2.0	2.0	38	1,700
240	18.3	645	2.6	1.2	2.0	2.1	41	2,000
300	20.3	803	2.8	1.2	2.0	2.2	44	2,300
400	23.2	1,027	3.0	1.2	2.0	2.3	47	2,700
500	26.2	1,305	3.2	1.3	2.5	2.5	52	3,300
630	30.0	1,720	3.2	1.4	2.5	2.6	57	4,000
800	34.0	2,200	3.2	1.4	2.5	2.7	61	4,700
1,000	38.2	2,750	3.2	1.5	2.5	2.9	66	5,500
1,200	43.0	3,290	3.2	1.6	2.5	3.0	71	6,400

Table 41

FRT-AL-XCTAH AL/XLPE/CTS/LSZH/AWA/LSZH (Single Core)

XLPE Insulated, LSZH Bedded, Aluminium Wire Armoured, LSZH Sheathed Cable
6.35/11KV (Max 12), IEC 60502-2

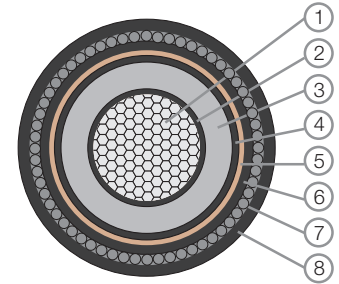
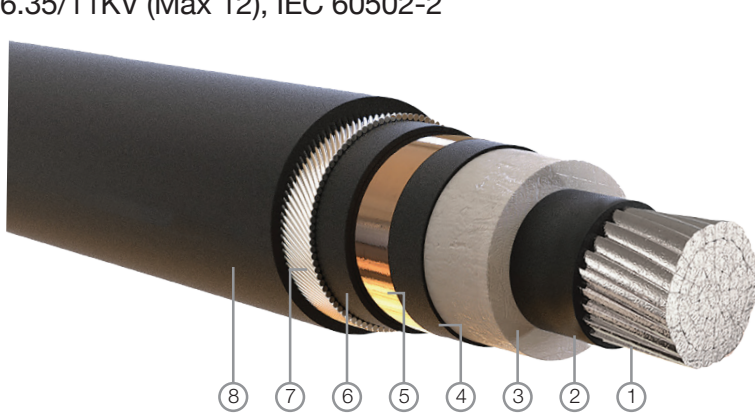

- Component**
1. Conductor
 2. Conductor screen
 3. Insulation
 4. Insulation screen
 5. Metallic screen (copper wire or copper tape)
 6. Inner sheath
 7. Armour
 8. Outer sheath

CONSTRUCTION

Conductor:	Plain Annealed Aluminium, Class 2 Conductor
Conductor Screen:	Extruded Semi Conductive Compound
Insulation:	Cross-linked Polyethylene (XLPE) Compound
Insulation Screen:	Extruded Semi Conductive Compound
Metallic Screen:	Copper Tape Screen
Inner Sheath:	LSZH Flame Retardant Polyolefin
Armour:	Aluminium Wire Armour (AWA) (DATA upon request)
Outer Sheath:	LSZH Flame Retardant Polyolefin
Outer Sheath Colour:	Black (other colours upon request)

ELECTRICAL CHARACTERISTICS

Operating Voltage:	6.35/11KV
Conductor Operating Temperature:	90°C
Final Short Circuit Temperature:	250°C
Test Voltage:	3.5U ₀

AL/XLPE/CTS/LSZH/AWA/LSZH (Single Core)

Nominal Area of Conductor (mm ²)	Nominal Diameter of Conductor (mm)	Approximate Weight of Conductor (kg/km)	Nominal Thickness of Insulation (mm)	Nominal Thickness of Inner Sheath (mm)	Nominal Armour Wire Diameter (mm)	Nominal Thickness of Outer Sheath (mm)	Approximate Overall Diameter (mm)	Approximate Cable Weight (kg/km)
70	9.7	182	3.4	1.2	1.6	1.9	33	1,200
95	11.3	251	3.4	1.2	1.6	1.9	34	1,300
120	12.8	317	3.4	1.2	1.6	2.0	36	1,500
150	14.2	390	3.4	1.2	2.0	2.1	38	1,600
185	15.9	493	3.4	1.2	2.0	2.1	40	1,900
240	18.3	645	3.4	1.2	2.0	2.2	43	2,100
300	20.3	803	3.4	1.2	2.0	2.2	45	2,400
400	23.2	1,027	3.4	1.2	2.0	2.4	48	2,800
500	26.2	1,305	3.4	1.3	2.5	2.5	52	3,400
630	30.0	1,720	3.4	1.4	2.5	2.6	57	4,100
800	34.0	2,200	3.4	1.4	2.5	2.7	61	4,700
1,000	38.2	2,750	3.4	1.5	2.5	2.9	66	5,600
1,200	43.0	3,290	3.4	1.6	2.5	3.0	72	6,400

Table 42

FRT-AL-XCTAH AL/XLPE/CTS/LSZH/AWA/LSZH (Single Core)

XLPE Insulated, LSZH Bedded, Aluminium Wire Armoured, LSZH Sheathed Cable
8.7/15KV (Max 17.5), IEC 60502-2

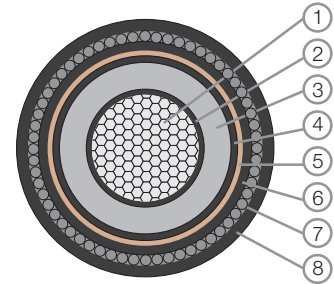
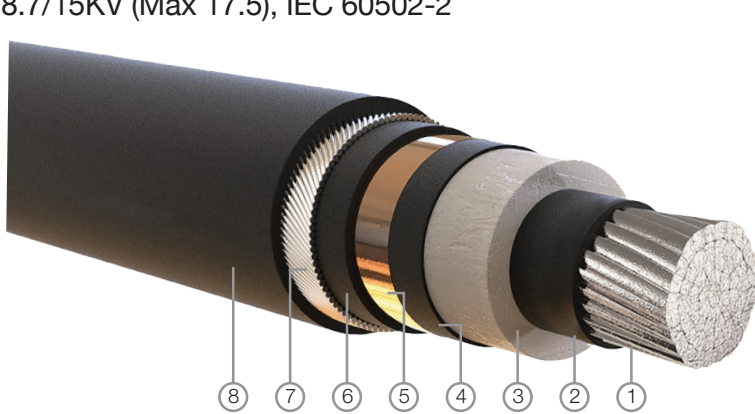

- Component**
1. Conductor
 2. Conductor screen
 3. Insulation
 4. Insulation screen
 5. Metallic screen (copper wire or copper tape)
 6. Inner sheath
 7. Armour
 8. Outer sheath

CONSTRUCTION

Conductor:	Plain Annealed Aluminium, Class 2 Conductor
Conductor Screen:	Extruded Semi Conductive Compound
Insulation:	Cross-linked Polyethylene (XLPE) Compound
Insulation Screen:	Extruded Semi Conductive Compound
Metallic Screen:	Copper Tape Screen
Inner Sheath:	LSZH Flame Retardant Polyolefin
Armour:	Aluminium Wire Armour (AWA) (DATA upon request)
Outer Sheath:	LSZH Flame Retardant Polyolefin
Outer Sheath Colour:	Black (other colours upon request)

ELECTRICAL CHARACTERISTICS

Operating Voltage:	8.7/15KV
Conductor Operating Temperature:	90°C
Final Short Circuit Temperature:	250°C
Test Voltage:	3.5U ₀

AL/XLPE/CTS/LSZH/AWA/LSZH (Single Core)

Nominal Area of Conductor (mm ²)	Nominal Diameter of Conductor (mm)	Approximate Weight of Conductor (kg/km)	Nominal Thickness of Insulation (mm)	Nominal Thickness of Inner Sheath (mm)	Nominal Armour Wire Diameter (mm)	Nominal Thickness of Outer Sheath (mm)	Approximate Overall Diameter (mm)	Approximate Cable Weight (kg/km)
70	9.7	182	4.5	1.2	1.6	1.9	35	1,300
95	11.3	251	4.5	1.2	2.0	2.0	38	1,500
120	12.8	317	4.5	1.2	2.0	2.1	40	1,700
150	14.2	390	4.5	1.2	2.0	2.1	41	1,850
185	15.9	493	4.5	1.2	2.0	2.2	43	2,000
240	18.3	645	4.5	1.2	2.0	2.3	46	2,300
300	20.3	803	4.5	1.2	2.0	2.3	48	2,600
400	23.2	1,027	4.5	1.3	2.5	2.5	53	3,100
500	26.2	1,305	4.5	1.3	2.5	2.6	56	3,600
630	30.0	1,720	4.5	1.4	2.5	2.7	60	4,300
800	34.0	2,200	4.5	1.5	2.5	2.8	65	5,000
1,000	38.2	2,750	4.5	1.6	2.5	3.0	69	5,900
1,200	43.0	3,290	4.5	1.7	2.5	3.2	75	6,800

Table 43

FRT-AL-XCTAH AL/XLPE/CTS/LSZH/AWA/LSZH (Single Core)

XLPE Insulated, LSZH Bedded, Aluminium Wire Armoured, LSZH Sheathed Cable
12.7/22KV (Max 24), IEC 60502-2

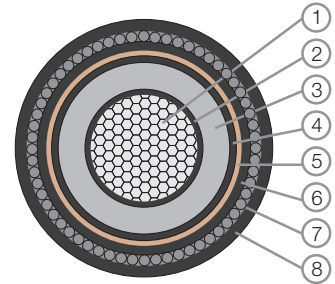
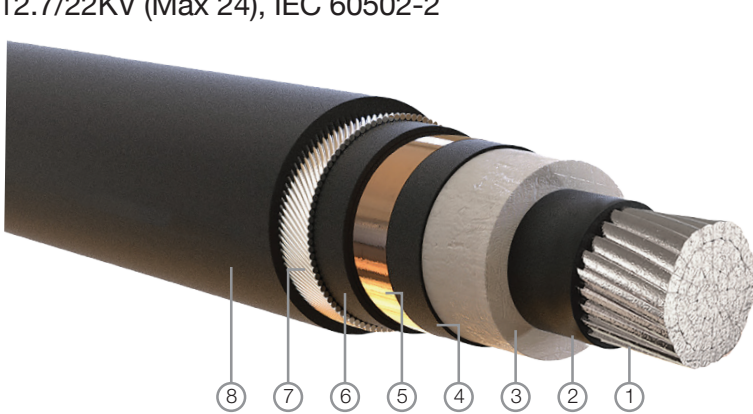

- Component**
1. Conductor
 2. Conductor screen
 3. Insulation
 4. Insulation screen
 5. Metallic screen (copper wire or copper tape)
 6. Inner sheath
 7. Armour
 8. Outer sheath

CONSTRUCTION

Conductor:	Plain Annealed Aluminium, Class 2 Conductor
Conductor Screen:	Extruded Semi Conductive Compound
Insulation:	Cross-linked Polyethylene (XLPE) Compound
Insulation Screen:	Extruded Semi Conductive Compound
Metallic Screen:	Copper Tape Screen
Inner Sheath:	LSZH Flame Retardant Polyolefin
Armour:	Aluminium Wire Armour (AWA) (DATA upon request)
Outer Sheath:	LSZH Flame Retardant Polyolefin
Outer Sheath Colour:	Black (other colours upon request)

ELECTRICAL CHARACTERISTICS

Operating Voltage:	12.7/22KV
Conductor Operating Temperature:	90°C
Final Short Circuit Temperature:	250°C
Test Voltage:	3.5U ₀

AL/XLPE/CTS/LSZH/AWA/LSZH (Single Core)

Nominal Area of Conductor (mm ²)	Nominal Diameter of Conductor (mm)	Approximate Weight of Conductor (kg/km)	Nominal Thickness of Insulation (mm)	Nominal Thickness of Inner Sheath (mm)	Nominal Armour Wire Diameter (mm)	Nominal Thickness of Outer Sheath (mm)	Approximate Overall Diameter (mm)	Approximate Cable Weight (kg/km)
70	9.7	182	5.5	1.2	2.0	2.0	38	1,500
95	11.3	251	5.5	1.2	2.0	2.1	40	1,700
120	12.8	317	5.5	1.2	2.0	2.1	42	1,800
150	14.2	390	5.5	1.2	2.0	2.2	43	2,000
185	15.9	493	5.5	1.2	2.0	2.2	45	2,200
240	18.3	645	5.5	1.2	2.0	2.3	48	2,500
300	20.3	803	5.5	1.3	2.5	2.4	51	2,900
400	23.2	1,027	5.5	1.3	2.5	2.5	54	3,300
500	26.2	1,305	5.5	1.4	2.5	2.6	58	3,800
630	30.0	1,720	5.5	1.4	2.5	2.8	62	4,500
800	34.0	2,200	5.5	1.5	2.5	2.9	66	5,300
1,000	38.2	2,750	5.5	1.6	2.5	3.0	71	6,100
1,200	43.0	3,290	5.5	1.7	2.5	3.2	77	7,000

Table 44

FRT-AL-XCTAH AL/XLPE/CTS/LSZH/AWA/LSZH (Single Core)

XLPE Insulated, LSZH Bedded, Aluminium Wire Armoured, LSZH Sheathed Cable
19/33KV (Max 36), IEC 60502-2

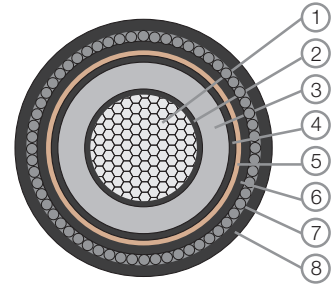
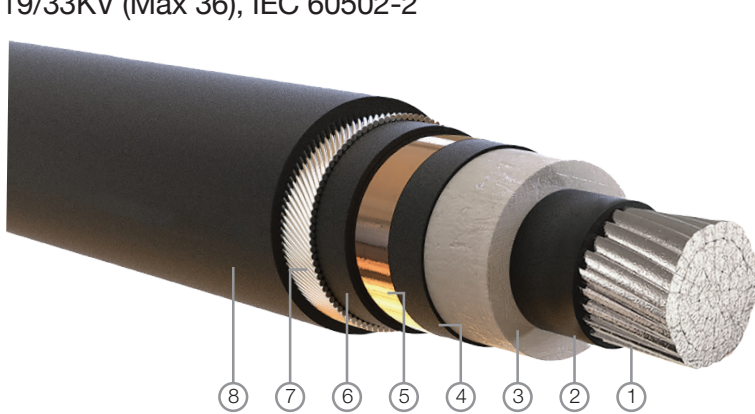

- Component**
1. Conductor
 2. Conductor screen
 3. Insulation
 4. Insulation screen
 5. Metallic screen (copper wire or copper tape)
 6. Inner sheath
 7. Armour
 8. Outer sheath

CONSTRUCTION

Conductor:	Plain Annealed Aluminium, Class 2 Conductor
Conductor Screen:	Extruded Semi Conductive Compound
Insulation:	Cross-linked Polyethylene (XLPE) Compound
Insulation Screen:	Extruded Semi Conductive Compound
Metallic Screen:	Copper Tape Screen
Inner Sheath:	LSZH Flame Retardant Polyolefin
Armour:	Aluminium Wire Armour (AWA) (DATA upon request)
Outer Sheath:	LSZH Flame Retardant Polyolefin
Outer Sheath Colour:	Black (other colours upon request)

ELECTRICAL CHARACTERISTICS

Operating Voltage:	19/33KV
Conductor Operating Temperature:	90°C
Final Short Circuit Temperature:	250°C
Test Voltage:	3.5U ₀

AL/XLPE/CTS/LSZH/AWA/LSZH (Single Core)

Nominal Area of Conductor (mm ²)	Nominal Diameter of Conductor (mm)	Approximate Weight of Conductor (kg/km)	Nominal Thickness of Insulation (mm)	Nominal Thickness of Inner Sheath (mm)	Nominal Armour Wire Diameter (mm)	Nominal Thickness of Outer Sheath (mm)	Approximate Overall Diameter (mm)	Approximate Cable Weight (kg/km)
70	9.7	182	8.0	1.2	2.0	2.2	43	1,900
95	11.3	251	8.0	1.2	2.0	2.3	45	2,100
120	12.8	317	8.0	1.2	2.0	2.3	47	2,200
150	14.2	390	8.0	1.3	2.0	2.4	48	2,400
185	15.9	493	8.0	1.3	2.5	2.5	51	2,900
240	18.3	645	8.0	1.3	2.5	2.5	54	3,240
300	20.3	803	8.0	1.4	2.5	2.6	56	3,600
400	23.2	1,027	8.0	1.4	2.5	2.7	59	4,100
500	26.2	1,305	8.0	1.5	2.5	2.8	63	4,600
630	30.0	1,720	8.0	1.5	2.5	2.9	67	5,400
800	34.0	2,200	8.0	1.6	2.5	3.1	71	6,200
1,000	38.2	2,750	8.0	1.7	2.5	3.2	76	7,500
1,200	43.0	3,290	8.0	1.8	2.5	3.3	81	8,700

Table 45

FRT-AL-XCTDAP AL/XLPE/CTS/LSZH/DATA/LSZH (Single Core)

XLPE Insulated, LSZH Bedded, Double Aluminium Tape Armoured, LSZH Sheathed Cable 3.8/6.6KV (Max 7.2), IEC 60502-2

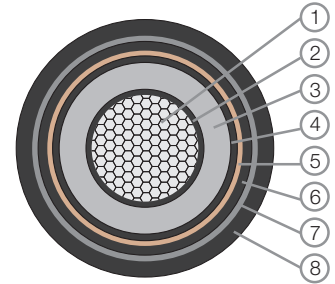
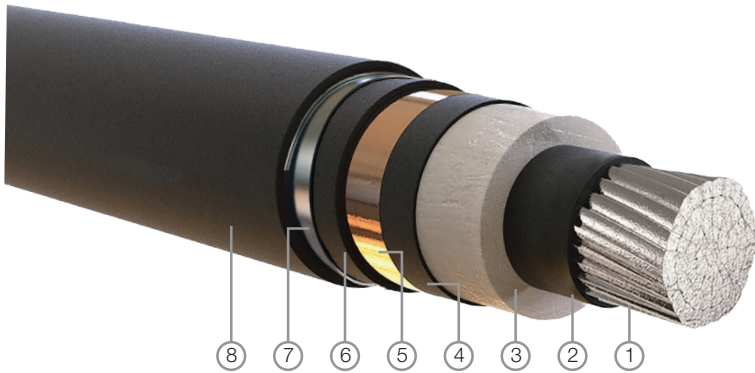

- Component**
1. Conductor
 2. Conductor screen
 3. Insulation
 4. Insulation screen
 5. Metallic screen (copper wire or copper tape)
 6. Inner sheath
 7. Armour
 8. Outer sheath

CONSTRUCTION

Conductor:	Plain Annealed Aluminium, Class 2 Conductor
Conductor Screen:	Extruded Semi Conductive Compound
Insulation:	Cross-linked Polyethylene (XLPE) Compound
Insulation Screen:	Extruded Semi Conductive Compound
Metallic Screen:	Copper Tape Screen
Inner Sheath:	LSZH Flame Retardant Polyolefin
Armour:	Double Aluminium Tape Armour (DATA)
Outer Sheath:	LSZH Flame Retardant Polyolefin
Outer Sheath Colour:	Black (other colours upon request)

ELECTRICAL CHARACTERISTICS

Operating Voltage:	3.8/6.6KV
Conductor Operating Temperature:	90°C
Final Short Circuit Temperature:	250°C
Test Voltage:	3.5U ₀

AL/XLPE/CTS/LSZH/DATA/LSZH (Single Core)

Nominal Area of Conductor (mm ²)	Nominal Diameter of Conductor (mm)	Approximate Weight of Conductor (kg/km)	Nominal Thickness of Insulation (mm)	Nominal Thickness of Inner Sheath (mm)	Nominal Thickness of Aluminium Tape (mm)	Nominal Thickness of Outer Sheath (mm)	Approximate Overall Diameter (mm)	Approximate Cable Weight (kg/km)
70	9.7	182	2.5	1.2	0.5	1.8	29	980
95	11.3	251	2.5	1.2	0.5	1.9	31	1,100
120	12.8	317	2.5	1.2	0.5	1.9	33	1,200
150	14.2	390	2.5	1.2	0.5	2.0	35	1,300
185	15.9	493	2.5	1.2	0.5	2.0	36	1,500
240	18.3	645	2.6	1.2	0.5	2.1	39	1,700
300	20.3	803	2.8	1.2	0.5	2.2	42	2,000
400	23.2	1,027	3.0	1.2	0.5	2.3	46	2,300
500	26.2	1,305	3.2	1.3	0.5	2.5	49	2,800
630	30.0	1,720	3.2	1.4	0.5	2.6	54	3,500
800	34.0	2,200	3.2	1.4	0.5	2.7	58	4,000
1,000	38.2	2,750	3.2	1.5	0.5	2.9	63	4,800
1,200	43.0	3,290	3.2	1.6	0.5	3.0	67	5,400

Table 46

FRT-AL-XCTDAP AL/XLPE/CTS/LSZH/DATA/LSZH (Single Core)

XLPE Insulated, LSZH Bedded, Double Aluminium Tape Armoured, LSZH Sheathed Cable 6.35/11KV (Max 12), IEC 60502-2

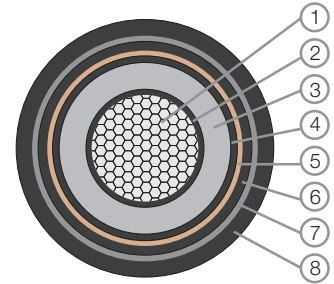
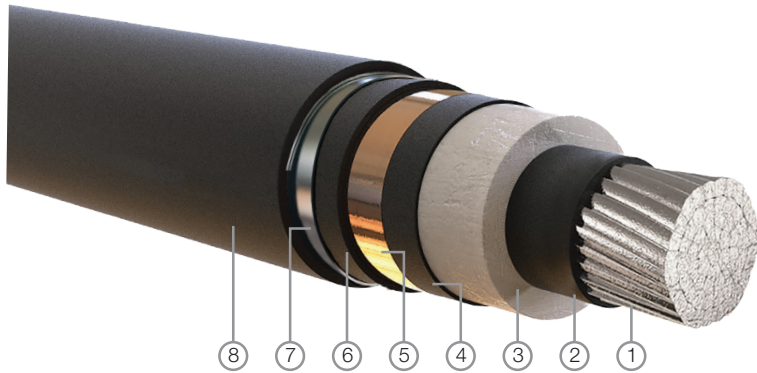

- Component**
1. Conductor
 2. Conductor screen
 3. Insulation
 4. Insulation screen
 5. Metallic screen (copper wire or copper tape)
 6. Inner sheath
 7. Armour
 8. Outer sheath

CONSTRUCTION

Conductor:	Plain Annealed Aluminium, Class 2 Conductor
Conductor Screen:	Extruded Semi Conductive Compound
Insulation:	Cross-linked Polyethylene (XLPE) Compound
Insulation Screen:	Extruded Semi Conductive Compound
Metallic Screen:	Copper Tape Screen
Inner Sheath:	LSZH Flame Retardant Polyolefin
Armour:	Double Aluminium Tape Armour (DATA)
Outer Sheath:	LSZH Flame Retardant Polyolefin
Outer Sheath Colour:	Black (other colours upon request)

ELECTRICAL CHARACTERISTICS

Operating Voltage:	6.35/11KV
Conductor Operating Temperature:	90°C
Final Short Circuit Temperature:	250°C
Test Voltage:	3.5U ₀

AL/XLPE/CTS/LSZH/DATA/LSZH (Single Core)

Nominal Area of Conductor (mm ²)	Nominal Diameter of Conductor (mm)	Approximate Weight of Conductor (kg/km)	Nominal Thickness of Insulation (mm)	Nominal Thickness of Inner Sheath (mm)	Nominal Thickness of Aluminium Tape (mm)	Nominal Thickness of Outer Sheath (mm)	Approximate Overall Diameter (mm)	Approximate Cable Weight (kg/km)
70	9.7	182	3.4	1.2	0.5	1.9	31	1,000
95	11.3	251	3.4	1.2	0.5	1.9	33	1,200
120	12.8	317	3.4	1.2	0.5	2.0	35	1,300
150	14.2	390	3.4	1.2	0.5	2.1	37	1,400
185	15.9	493	3.4	1.2	0.5	2.1	38	1,600
240	18.3	645	3.4	1.2	0.5	2.2	41	1,800
300	20.3	803	3.4	1.2	0.5	2.2	43	2,100
400	23.2	1,027	3.4	1.2	0.5	2.4	47	2,400
500	26.2	1,305	3.4	1.3	0.5	2.5	50	2,900
630	30.0	1,720	3.4	1.4	0.5	2.6	55	3,600
800	34.0	2,200	3.4	1.4	0.5	2.7	59	4,100
1,000	38.2	2,750	3.4	1.5	0.5	2.9	64	4,900
1,200	43.0	3,290	3.4	1.6	0.5	3.0	68	5,500

Table 47

FRT-AL-XCTDAP AL/XLPE/CTS/LSZH/DATA/LSZH (Single Core)

XLPE Insulated, LSZH Bedded, Double Aluminium Tape Armoured, LSZH Sheathed Cable 8.7/15KV (Max 17.5), IEC 60502-2

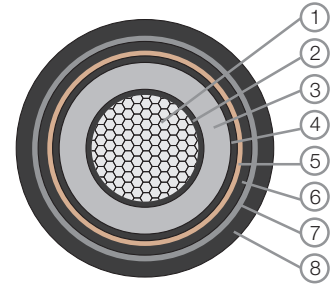
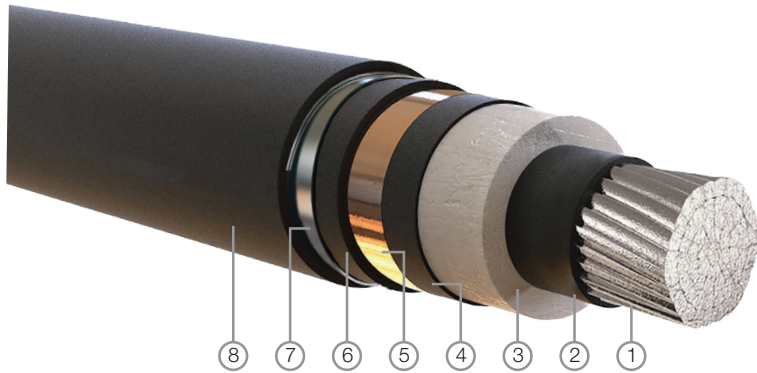

- Component**
1. Conductor
 2. Conductor screen
 3. Insulation
 4. Insulation screen
 5. Metallic screen (copper wire or copper tape)
 6. Inner sheath
 7. Armour
 8. Outer sheath

CONSTRUCTION

Conductor:	Plain Annealed Aluminium, Class 2 Conductor
Conductor Screen:	Extruded Semi Conductive Compound
Insulation:	Cross-linked Polyethylene (XLPE) Compound
Insulation Screen:	Extruded Semi Conductive Compound
Metallic Screen:	Copper Tape Screen
Inner Sheath:	LSZH Flame Retardant Polyolefin
Armour:	Double Aluminium Tape Armour (DATA)
Outer Sheath:	LSZH Flame Retardant Polyolefin
Outer Sheath Colour:	Black (other colours upon request)

ELECTRICAL CHARACTERISTICS

Operating Voltage:	8.7/15KV
Conductor Operating Temperature:	90°C
Final Short Circuit Temperature:	250°C
Test Voltage:	3.5U ₀

AL/XLPE/CTS/LSZH/DATA/LSZH (Single Core)

Nominal Area of Conductor (mm ²)	Nominal Diameter of Conductor (mm)	Approximate Weight of Conductor (kg/km)	Nominal Thickness of Insulation (mm)	Nominal Thickness of Inner Sheath (mm)	Nominal Thickness of Aluminium Tape (mm)	Nominal Thickness of Outer Sheath (mm)	Approximate Overall Diameter (mm)	Approximate Cable Weight (kg/km)
70	9.7	182	4.5	1.2	0.5	1.9	33	1,200
95	11.3	251	4.5	1.2	0.5	2.0	35	1,300
120	12.8	317	4.5	1.2	0.5	2.1	37	1,500
150	14.2	390	4.5	1.2	0.5	2.1	39	1,600
185	15.9	493	4.5	1.2	0.5	2.2	41	1,800
240	18.3	645	4.5	1.2	0.5	2.3	43	2,000
300	20.3	803	4.5	1.2	0.5	2.3	45	2,300
400	23.2	1,027	4.5	1.3	0.5	2.5	49	2,600
500	26.2	1,305	4.5	1.3	0.5	2.6	52	3,000
630	30.0	1,720	4.5	1.4	0.5	2.7	56	3,700
800	34.0	2,200	4.5	1.5	0.5	2.8	61	4,300
1,000	38.2	2,750	4.5	1.6	0.5	3.0	66	5,100
1,200	43.0	3,290	4.5	1.7	0.5	3.2	70	5,800

Table 48

FRT-AL-XCTDAP AL/XLPE/CTS/LSZH/DATA/LSZH (Single Core)

XLPE Insulated, LSZH Bedded, Double Aluminium Tape Armoured, LSZH Sheathed Cable 12.7/22KV (Max 24), IEC 60502-2

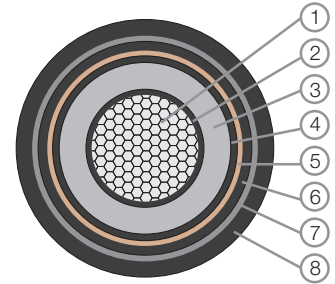
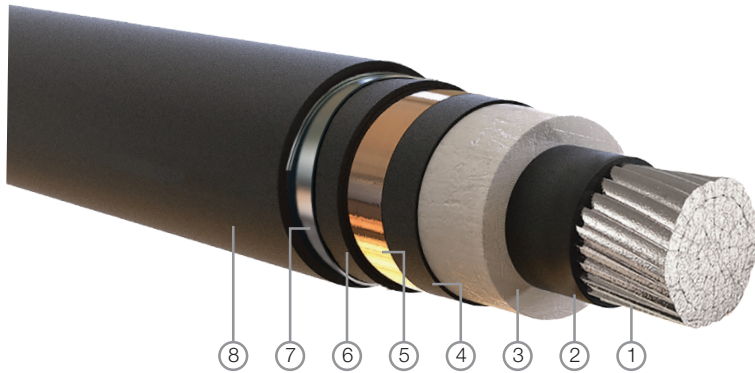

- Component**
1. Conductor
 2. Conductor screen
 3. Insulation
 4. Insulation screen
 5. Metallic screen (copper wire or copper tape)
 6. Inner sheath
 7. Armour
 8. Outer sheath

CONSTRUCTION

Conductor:	Plain Annealed Aluminium, Class 2 Conductor
Conductor Screen:	Extruded Semi Conductive Compound
Insulation:	Cross-linked Polyethylene (XLPE) Compound
Insulation Screen:	Extruded Semi Conductive Compound
Metallic Screen:	Copper Tape Screen
Inner Sheath:	LSZH Flame Retardant Polyolefin
Armour:	Double Aluminium Tape Armour (DATA)
Outer Sheath:	LSZH Flame Retardant Polyolefin
Outer Sheath Colour:	Black (other colours upon request)

ELECTRICAL CHARACTERISTICS

Operating Voltage:	12.7/22KV
Conductor Operating Temperature:	90°C
Final Short Circuit Temperature:	250°C
Test Voltage:	3.5U ₀

AL/XLPE/CTS/LSZH/DATA/LSZH (Single Core)

Nominal Area of Conductor (mm ²)	Nominal Diameter of Conductor (mm)	Approximate Weight of Conductor (kg/km)	Nominal Thickness of Insulation (mm)	Nominal Thickness of Inner Sheath (mm)	Nominal Thickness of Aluminium Tape (mm)	Nominal Thickness of Outer Sheath (mm)	Approximate Overall Diameter (mm)	Approximate Cable Weight (kg/km)
70	9.7	182	5.5	1.2	0.5	2.0	37	1,400
95	11.3	251	5.5	1.2	0.5	2.1	39	1,500
120	12.8	317	5.5	1.2	0.5	2.1	40	1,600
150	14.2	390	5.5	1.2	0.5	2.2	42	1,800
185	15.9	493	5.5	1.2	0.5	2.2	44	2,000
240	18.3	645	5.5	1.2	0.5	2.3	46	2,200
300	20.3	803	5.5	1.3	0.5	2.4	49	2,500
400	23.2	1,027	5.5	1.3	0.5	2.5	52	2,900
500	26.2	1,305	5.5	1.4	0.5	2.6	55	3,300
630	30.0	1,720	5.5	1.4	0.5	2.8	60	4,000
800	34.0	2,200	5.5	1.5	0.5	2.9	64	4,600
1,000	38.2	2,750	5.5	1.6	0.5	3.0	69	5,400
1,200	43.0	3,290	5.5	1.7	0.5	3.2	73	6,100

Table 49

FRT-AL-XCTDAP AL/XLPE/CTS/LSZH/DATA/LSZH (Single Core)

XLPE Insulated, LSZH Bedded, Double Aluminium Tape Armoured, LSZH Sheathed Cable 19/33KV (Max 36), IEC 60502-2

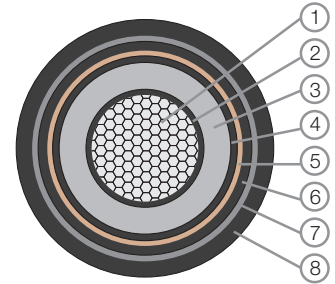
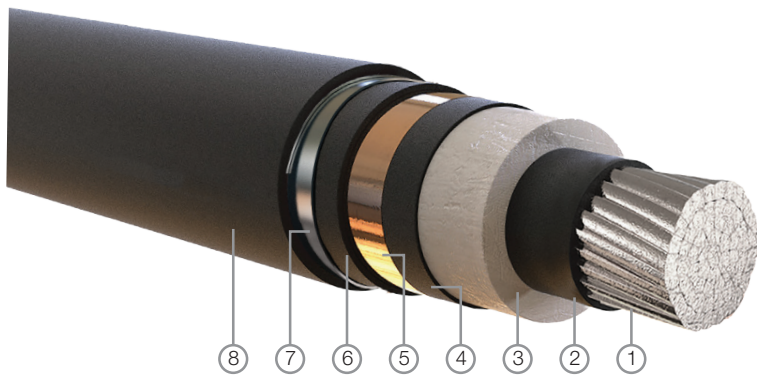

- Component**
1. Conductor
 2. Conductor screen
 3. Insulation
 4. Insulation screen
 5. Metallic screen (copper wire or copper tape)
 6. Inner sheath
 7. Armour
 8. Outer sheath

CONSTRUCTION

Conductor:	Plain Annealed Aluminium, Class 2 Conductor
Conductor Screen:	Extruded Semi Conductive Compound
Insulation:	Cross-linked Polyethylene (XLPE) Compound
Insulation Screen:	Extruded Semi Conductive Compound
Metallic Screen:	Copper Tape Screen
Inner Sheath:	LSZH Flame Retardant Polyolefin
Armour:	Double Aluminium Tape Armour (DATA)
Outer Sheath:	LSZH Flame Retardant Polyolefin
Outer Sheath Colour:	Black (other colours upon request)

ELECTRICAL CHARACTERISTICS

Operating Voltage:	19/33KV
Conductor Operating Temperature:	90°C
Final Short Circuit Temperature:	250°C
Test Voltage:	3.5U ₀

AL/XLPE/CTS/LSZH/DATA/LSZH (Single Core)

Nominal Area of Conductor (mm ²)	Nominal Diameter of Conductor (mm)	Approximate Weight of Conductor (kg/km)	Nominal Thickness of Insulation (mm)	Nominal Thickness of Inner Sheath (mm)	Nominal Thickness of Aluminium Tape (mm)	Nominal Thickness of Outer Sheath (mm)	Approximate Overall Diameter (mm)	Approximate Cable Weight (kg/km)
70	9.7	182	8.0	1.2	0.5	2.2	42	1,700
95	11.3	251	8.0	1.2	0.5	2.3	44	1,900
120	12.8	317	8.0	1.2	0.5	2.3	46	2,000
150	14.2	390	8.0	1.3	0.5	2.4	48	2,200
185	15.9	493	8.0	1.3	0.5	2.5	59	2,400
240	18.3	645	8.0	1.3	0.5	2.5	52	2,700
300	20.3	803	8.0	1.4	0.5	2.6	54	3,000
400	23.2	1,027	8.0	1.4	0.5	2.7	58	3,300
500	26.2	1,305	8.0	1.5	0.5	2.8	61	3,800
630	30.0	1,720	8.0	1.5	0.5	2.9	65	4,500
800	34.0	2,200	8.0	1.6	0.5	3.1	69	5,200
1,000	38.2	2,750	8.0	1.7	0.5	3.2	74	6,000
1,200	43.0	3,290	8.0	1.8	0.5	3.3	78	6,700

Table 50

FRT-AL-XCTDH AL/XLPE/CTS/LSZH/DSTA/LSZH (Three Core)

XLPE Insulated, LSZH Bedded, Double Steel Tape Armoured, LSZH Sheathed Cable
3.8/6.6KV (Max 7.2), IEC 60502-2

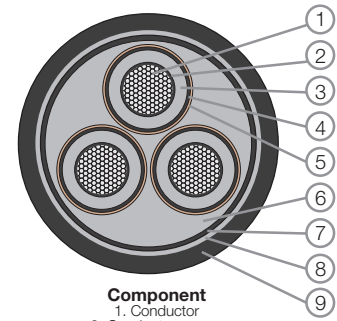
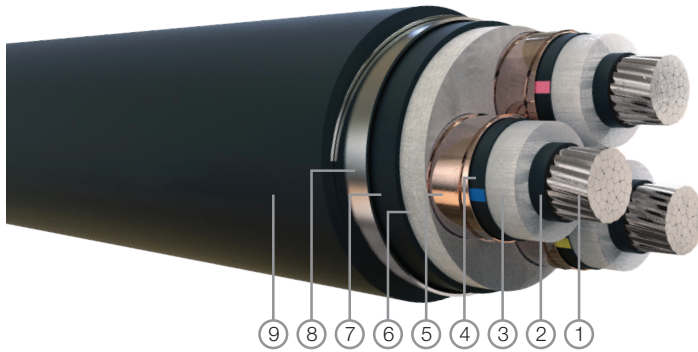

- Component**
1. Conductor
 2. Conductor screen
 3. Insulation
 4. Insulation screen
 5. Metallic screen (copper wire or copper tape)
 6. Filler & Binder Tape
 7. Inner sheath
 8. Armour
 9. Outer sheath

CONSTRUCTION

Conductor:	Plain Annealed Aluminium, Class 2 Conductor
Conductor Screen:	Extruded Semi Conductive Compound
Insulation:	Cross-linked Polyethylene (XLPE) Compound
Insulation Screen:	Extruded Semi Conductive Compound
Metallic Screen:	Copper Tape Screen
Assembled Core:	PP Yarn Filler with Binder Tape
Inner Sheath:	LSZH Flame Retardant Polyolefin
Armour:	Double Steel Tape Armour (DSTA)
Outer Sheath:	LSZH Flame Retardant Polyolefin
Outer Sheath Colour:	Black (other colours upon request)

ELECTRICAL CHARACTERISTICS

Operating Voltage:	3.8/6.6KV
Conductor Operating Temperature:	90°C
Final Short Circuit Temperature:	250°C
Test Voltage:	3.5U ₀

AL/XLPE/CTS/LSZH/DSTA/LSZH (Three Core)

Nominal Area of Conductor (mm ²)	Nominal Diameter of Conductor (mm)	Approximate Weight of Conductor (kg/km)	Nominal Thickness of Insulation (mm)	Nominal Thickness of Inner Sheath (mm)	Nominal Thickness of Steel Tape (mm)	Nominal Thickness of Outer Sheath (mm)	Approximate Overall Diameter (mm)	Approximate Cable Weight (kg/km)
50	8.2	383	2.5	1.3	0.5	2.4	49	3,000
70	9.7	557	2.5	1.4	0.5	2.5	53	3,500
95	11.3	768	2.5	1.4	0.5	2.6	56	4,000
120	12.8	970	2.5	1.5	0.5	2.7	60	4,600
150	14.2	1,193	2.5	1.5	0.5	2.8	63	5,100
185	15.9	1,509	2.5	1.6	0.5	2.9	67	5,800
240	18.3	1,974	2.6	1.7	0.5	3.1	73	6,900
300	20.3	2,457	2.8	1.8	0.5	3.3	79	8,600
400	23.2	3,142	3.0	2.0	0.8	3.6	88	11,000

Table 51

FRT-AL-XCTDH AL/XLPE/CTS/LSZH/DSTA/LSZH (Three Core)

XLPE Insulated, LSZH Bedded, Double Steel Tape Armoured, LSZH Sheathed Cable
6.35/11KV (Max 12), IEC 60502-2

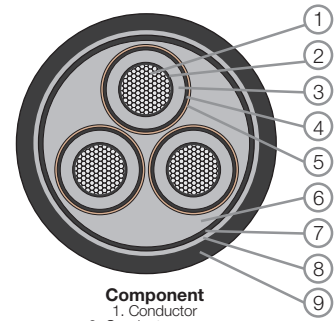
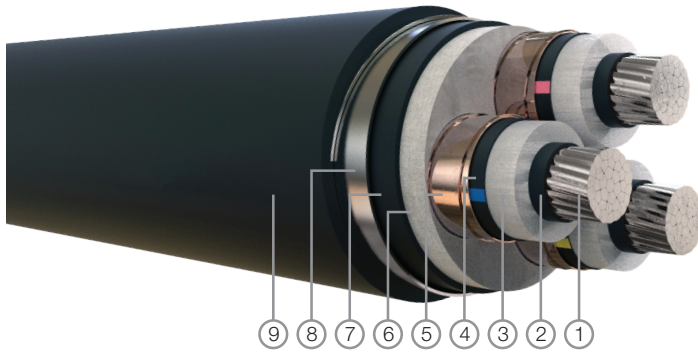

- Component**
1. Conductor
 2. Conductor screen
 3. Insulation
 4. Insulation screen
 5. Metallic screen (copper wire or copper tape)
 6. Filler & Binder Tape
 7. Inner sheath
 8. Armour
 9. Outer sheath

CONSTRUCTION

Conductor:	Plain Annealed Aluminium, Class 2 Conductor
Conductor Screen:	Extruded Semi Conductive Compound
Insulation:	Cross-linked Polyethylene (XLPE) Compound
Insulation Screen:	Extruded Semi Conductive Compound
Metallic Screen:	Copper Tape Screen
Assembled Core:	PP Yarn Filler with Binder Tape
Inner Sheath:	LSZH Flame Retardant Polyolefin
Armour:	Double Steel Tape Armour (DSTA)
Outer Sheath:	LSZH Flame Retardant Polyolefin
Outer Sheath Colour:	Black (other colours upon request)

ELECTRICAL CHARACTERISTICS

Operating Voltage:	6.35/11KV
Conductor Operating Temperature:	90°C
Final Short Circuit Temperature:	250°C
Test Voltage:	3.5U ₀

AL/XLPE/CTS/LSZH/DSTA/LSZH (Three Core)

Nominal Area of Conductor (mm ²)	Nominal Diameter of Conductor (mm)	Approximate Weight of Conductor (kg/km)	Nominal Thickness of Insulation (mm)	Nominal Thickness of Inner Sheath (mm)	Nominal Thickness of Steel Tape (mm)	Nominal Thickness of Outer Sheath (mm)	Approximate Overall Diameter (mm)	Approximate Cable Weight (kg/km)
50	8.2	383	3.4	1.4	0.5	2.5	53	3,400
70	9.7	557	3.4	1.4	0.5	2.6	56	3,900
95	11.3	768	3.4	1.5	0.5	2.7	60	4,500
120	12.8	970	3.4	1.6	0.5	2.9	64	5,100
150	14.2	1,193	3.4	1.6	0.5	3.0	67	5,600
185	15.9	1,509	3.4	1.7	0.5	3.1	71	6,300
240	18.3	1,974	3.4	1.8	0.5	3.3	77	7,400
300	20.3	2,457	3.4	1.9	0.5	3.4	82	9,000
400	23.2	3,142	3.4	2.0	0.8	3.7	90	11,600

Table 52

FRT-AL-XCTDH AL/XLPE/CTS/LSZH/DSTA/LSZH (Three Core)

XLPE Insulated, LSZH Bedded, Double Steel Tape Armoured, LSZH Sheathed Cable
8.7/15KV (Max 17.5), IEC 60502-2

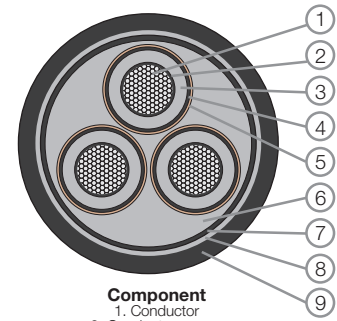
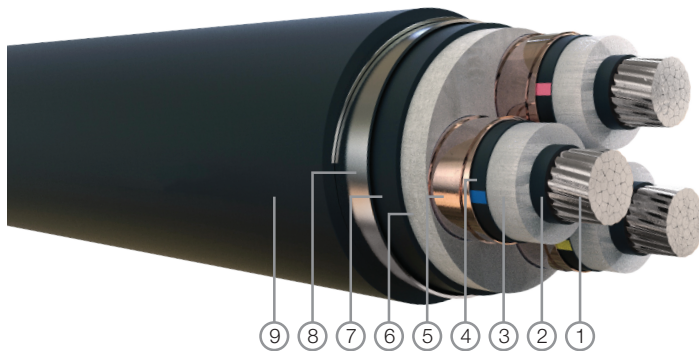

- Component**
1. Conductor
 2. Conductor screen
 3. Insulation
 4. Insulation screen
 5. Metallic screen (copper wire or copper tape)
 6. Filler & Binder Tape
 7. Inner sheath
 8. Armour
 9. Outer sheath

CONSTRUCTION

Conductor:	Plain Annealed Aluminium, Class 2 Conductor
Conductor Screen:	Extruded Semi Conductive Compound
Insulation:	Cross-linked Polyethylene (XLPE) Compound
Insulation Screen:	Extruded Semi Conductive Compound
Metallic Screen:	Copper Tape Screen
Assembled Core:	PP Yarn Filler with Binder Tape
Inner Sheath:	LSZH Flame Retardant Polyolefin
Armour:	Double Steel Tape Armour (DSTA)
Outer Sheath:	LSZH Flame Retardant Polyolefin
Outer Sheath Colour:	Black (other colours upon request)

ELECTRICAL CHARACTERISTICS

Operating Voltage:	8.7/15KV
Conductor Operating Temperature:	90°C
Final Short Circuit Temperature:	250°C
Test Voltage:	3.5U ₀

AL/XLPE/CTS/LSZH/DSTA/LSZH (Three Core)

Nominal Area of Conductor (mm ²)	Nominal Diameter of Conductor (mm)	Approximate Weight of Conductor (kg/km)	Nominal Thickness of Insulation (mm)	Nominal Thickness of Inner Sheath (mm)	Nominal Thickness of Steel Tape (mm)	Nominal Thickness of Outer Sheath (mm)	Approximate Overall Diameter (mm)	Approximate Cable Weight (kg/km)
50	8.2	383	4.5	1.5	0.5	2.7	58	4,100
70	9.7	557	4.5	1.5	0.5	2.8	61	4,600
95	11.3	768	4.5	1.6	0.5	2.9	65	5,200
120	12.8	970	4.5	1.7	0.5	3.0	69	5,900
150	14.2	1,193	4.5	1.7	0.5	3.1	72	6,400
185	15.9	1,509	4.5	1.8	0.5	3.3	76	7,100
240	18.3	1,974	4.5	1.9	0.5	3.4	82	8,200
300	20.3	2,457	4.5	2.0	0.8	3.6	88	11,000
400	23.2	3,142	4.5	2.1	0.8	3.9	95	12,500

Table 53

FRT-AL-XCTDH AL/XLPE/CTS/LSZH/DSTA/LSZH (Three Core)

XLPE Insulated, LSZH Bedded, Double Steel Tape Armoured, LSZH Sheathed Cable
12.7/22KV (Max 24), IEC 60502-2

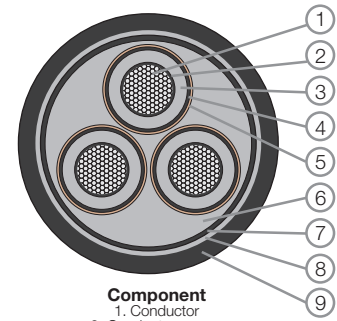
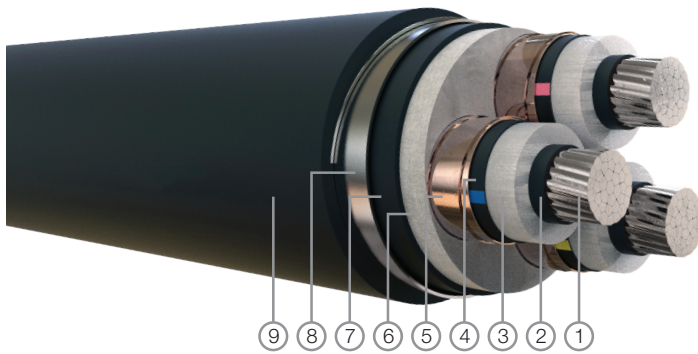

- Component**
1. Conductor
 2. Conductor screen
 3. Insulation
 4. Insulation screen
 5. Metallic screen (copper wire or copper tape)
 6. Filler & Binder Tape
 7. Inner sheath
 8. Armour
 9. Outer sheath

CONSTRUCTION

Conductor:	Plain Annealed Aluminium, Class 2 Conductor
Conductor Screen:	Extruded Semi Conductive Compound
Insulation:	Cross-linked Polyethylene (XLPE) Compound
Insulation Screen:	Extruded Semi Conductive Compound
Metallic Screen:	Copper Tape Screen
Assembled Core:	PP Yarn Filler with Binder Tape
Inner Sheath:	LSZH Flame Retardant Polyolefin
Armour:	Double Steel Tape Armour (DSTA)
Outer Sheath:	LSZH Flame Retardant Polyolefin
Outer Sheath Colour:	Black (other colours upon request)

ELECTRICAL CHARACTERISTICS

Operating Voltage:	12.7/22KV
Conductor Operating Temperature:	90°C
Final Short Circuit Temperature:	250°C
Test Voltage:	3.5U ₀

AL/XLPE/CTS/LSZH/DSTA/LSZH (Three Core)

Nominal Area of Conductor (mm ²)	Nominal Diameter of Conductor (mm)	Approximate Weight of Conductor (kg/km)	Nominal Thickness of Insulation (mm)	Nominal Thickness of Inner Sheath (mm)	Nominal Thickness of Steel Tape (mm)	Nominal Thickness of Outer Sheath (mm)	Approximate Overall Diameter (mm)	Approximate Cable Weight (kg/km)
50	8.2	383	5.5	1.6	0.5	2.8	63	4,400
70	9.7	557	5.5	1.6	0.5	2.9	66	5,000
95	11.3	768	5.5	1.7	0.5	3.1	70	5,600
120	12.8	970	5.5	1.7	0.5	3.2	73	6,200
150	14.2	1,193	5.5	1.8	0.5	3.3	77	6,700
185	15.9	1,509	5.5	1.9	0.5	3.4	81	7,600
240	18.3	1,974	5.5	2.0	0.8	3.6	88	9,700
300	20.3	2,457	5.5	2.0	0.8	3.8	92	11,500
400	23.2	3,142	5.5	2.2	0.8	4.0	100	13,000

Table 54

FRT-AL-XCTDH AL/XLPE/CTS/LSZH/DSTA/LSZH (Three Core)

XLPE Insulated, LSZH Bedded, Double Steel Tape Armoured, LSZH Sheathed Cable
19/33KV (Max 36), IEC 60502-2

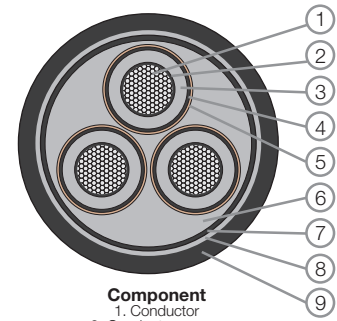
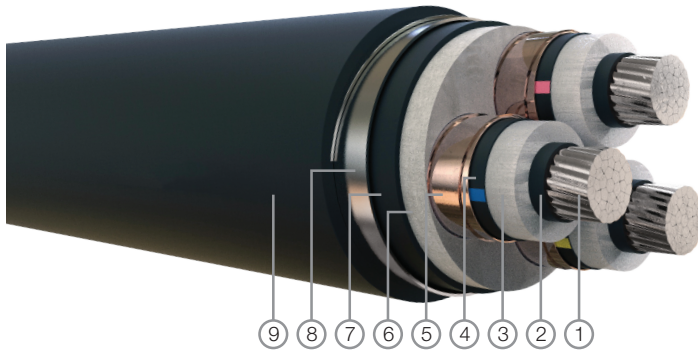

- Component**
1. Conductor
 2. Conductor screen
 3. Insulation
 4. Insulation screen
 5. Metallic screen (copper wire or copper tape)
 6. Filler & Binder Tape
 7. Inner sheath
 8. Armour
 9. Outer sheath

CONSTRUCTION

Conductor:	Plain Annealed Aluminium, Class 2 Conductor
Conductor Screen:	Extruded Semi Conductive Compound
Insulation:	Cross-linked Polyethylene (XLPE) Compound
Insulation Screen:	Extruded Semi Conductive Compound
Metallic Screen:	Copper Tape Screen
Assembled Core:	PP Yarn Filler with Binder Tape
Inner Sheath:	LSZH Flame Retardant Polyolefin
Armour:	Double Steel Tape Armour (DSTA)
Outer Sheath:	LSZH Flame Retardant Polyolefin
Outer Sheath Colour:	Black (other colours upon request)

ELECTRICAL CHARACTERISTICS

Operating Voltage:	19/33KV
Conductor Operating Temperature:	90°C
Final Short Circuit Temperature:	250°C
Test Voltage:	3.5U ₀

AL/XLPE/CTS/LSZH/DSTA/LSZH (Three Core)

Nominal Area of Conductor (mm ²)	Nominal Diameter of Conductor (mm)	Approximate Weight of Conductor (kg/km)	Nominal Thickness of Insulation (mm)	Nominal Thickness of Inner Sheath (mm)	Nominal Thickness of Steel Tape (mm)	Nominal Thickness of Outer Sheath (mm)	Approximate Overall Diameter (mm)	Approximate Cable Weight (kg/km)
50	8.2	383	8.0	1.8	0.5	3.2	74	5,900
70	9.7	557	8.0	1.8	0.5	3.3	78	6,500
95	11.3	768	8.0	1.9	0.5	3.5	82	7,100
120	12.8	970	8.0	2.0	0.8	3.6	87	8,700
150	14.2	1,193	8.0	2.0	0.8	3.7	90	9,100
185	15.9	1,509	8.0	2.1	0.8	3.9	94	10,000
240	18.3	1,974	8.0	2.2	0.8	4.0	100	11,000
300	20.3	2,457	8.0	2.3	0.8	4.2	105	13,000
400	23.2	3,142	8.0	2.4	0.8	4.4	112	14,000

Table 55

FRT-AL-XCTSH AL/XLPE/CTS/LSZH/SWA/LSZH (Three Core)

XLPE Insulated, LSZH Bedded, Steel Wire Armoured, LSZH Sheathed Cable
3.8/6.6KV (Max 7.2), IEC 60502-2

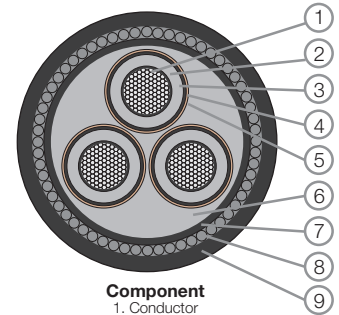
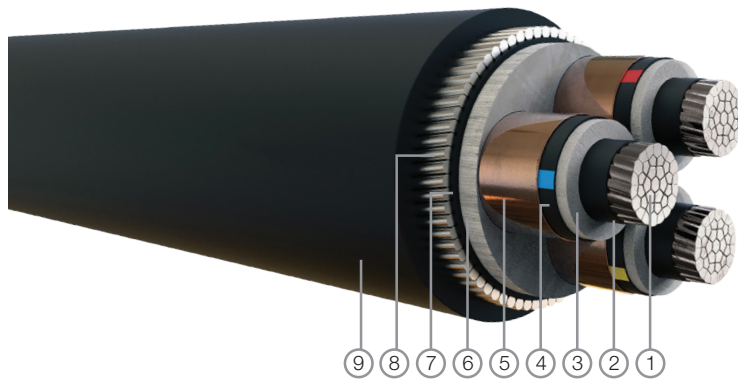

- Component**
1. Conductor
 2. Conductor screen
 3. Insulation
 4. Insulation screen
 5. Metallic screen (copper wire or copper tape)
 6. Filler & Binder Tape
 7. Inner sheath
 8. Armour
 9. Outer sheath

CONSTRUCTION

Conductor:	Plain Annealed Aluminium, Class 2 Conductor
Conductor Screen:	Extruded Semi Conductive Compound
Insulation:	Cross-linked Polyethylene (XLPE) Compound
Insulation Screen:	Extruded Semi Conductive Compound
Metallic Screen:	Copper Tape Screen
Assembled Core:	PP Yarn Filler with Binder Tape
Inner Sheath:	LSZH Flame Retardant Polyolefin
Armour:	Steel Wire Armour (SWA)
Outer Sheath:	LSZH Flame Retardant Polyolefin
Outer Sheath Colour:	Black (other colours upon request)

ELECTRICAL CHARACTERISTICS

Operating Voltage:	3.8/6.6KV
Conductor Operating Temperature:	90°C
Final Short Circuit Temperature:	250°C
Test Voltage:	3.5U ₀

AL/XLPE/CTS/LSZH/SWA/LSZH (Three Core)

Nominal Area of Conductor (mm ²)	Nominal Diameter of Conductor (mm)	Approximate Weight of Conductor (kg/km)	Nominal Thickness of Insulation (mm)	Nominal Thickness of Inner Sheath (mm)	Nominal Armour Wire Diameter (mm)	Nominal Thickness of Outer Sheath (mm)	Approximate Overall Diameter (mm)	Approximate Cable Weight (kg/km)
50	8.2	383	2.5	1.3	2.5	2.5	52	4,400
70	9.7	557	2.5	1.4	2.5	2.6	56	5,000
95	11.3	768	2.5	1.4	2.5	2.7	60	5,700
120	12.8	970	2.5	1.5	2.5	2.8	64	6,300
150	14.2	1,193	2.5	1.5	2.5	2.9	67	7,000
185	15.9	1,509	2.5	1.6	2.5	3.0	71	7,900
240	18.3	1,974	2.6	1.7	2.5	3.2	77	9,200
300	20.3	2,457	2.8	1.8	3.15	3.5	84	12,000
400	23.2	3,142	3.0	2.0	3.15	3.8	93	14,000

Table 56

FRT-AL-XCTSH AL/XLPE/CTS/LSZH/SWA/LSZH (Three Core)

XLPE Insulated, LSZH Bedded, Steel Wire Armoured, LSZH Sheathed Cable
6.35/11KV (Max 12), IEC 60502-2

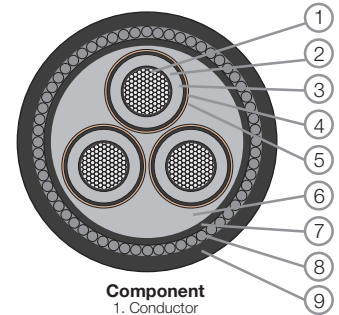
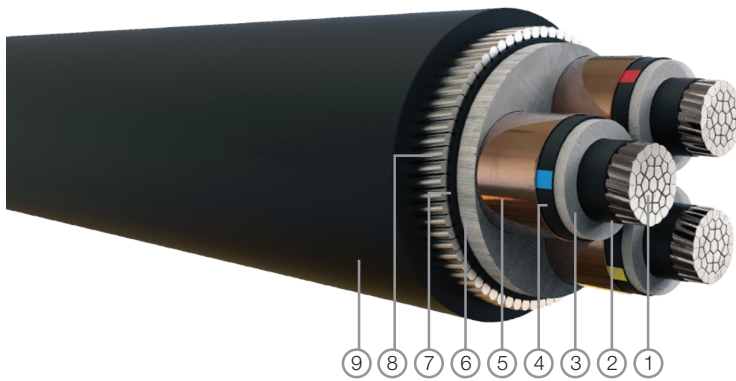

- Component**
1. Conductor
 2. Conductor screen
 3. Insulation
 4. Insulation screen
 5. Metallic screen (copper wire or copper tape)
 6. Filler & Binder Tape
 7. Inner sheath
 8. Armour
 9. Outer sheath

CONSTRUCTION

Conductor:	Plain Annealed Aluminium, Class 2 Conductor
Conductor Screen:	Extruded Semi Conductive Compound
Insulation:	Cross-linked Polyethylene (XLPE) Compound
Insulation Screen:	Extruded Semi Conductive Compound
Metallic Screen:	Copper Tape Screen
Assembled Core:	PP Yarn Filler with Binder Tape
Inner Sheath:	LSZH Flame Retardant Polyolefin
Armour:	Steel Wire Armour (SWA)
Outer Sheath:	LSZH Flame Retardant Polyolefin
Outer Sheath Colour:	Black (other colours upon request)

ELECTRICAL CHARACTERISTICS

Operating Voltage:	6.35/11KV
Conductor Operating Temperature:	90°C
Final Short Circuit Temperature:	250°C
Test Voltage:	3.5U ₀

AL/XLPE/CTS/LSZH/SWA/LSZH (Three Core)

Nominal Area of Conductor (mm ²)	Nominal Diameter of Conductor (mm)	Approximate Weight of Conductor (kg/km)	Nominal Thickness of Insulation (mm)	Nominal Thickness of Inner Sheath (mm)	Nominal Armour Wire Diameter (mm)	Nominal Thickness of Outer Sheath (mm)	Approximate Overall Diameter (mm)	Approximate Cable Weight (kg/km)
50	8.2	383	3.4	1.4	2.5	2.6	56	5,000
70	9.7	557	3.4	1.4	2.5	2.7	60	5,600
95	11.3	768	3.4	1.5	2.5	2.9	64	6,300
120	12.8	970	3.4	1.6	2.5	3.0	68	6,900
150	14.2	1,193	3.4	1.6	2.5	3.1	71	7,600
185	15.9	1,509	3.4	1.7	2.5	3.2	75	8,600
240	18.3	1,974	3.4	1.8	3.15	3.4	82	10,700
300	20.3	2,457	3.4	1.9	3.15	3.5	87	12,800
400	23.2	3,142	3.4	2.0	3.15	3.8	95	14,600

Table 57

FRT-AL-XCTSH AL/XLPE/CTS/LSZH/SWA/LSZH (Three Core)

XLPE Insulated, LSZH Bedded, Steel Wire Armoured, LSZH Sheathed Cable
8.7/15KV (Max 17.5), IEC 60502-2

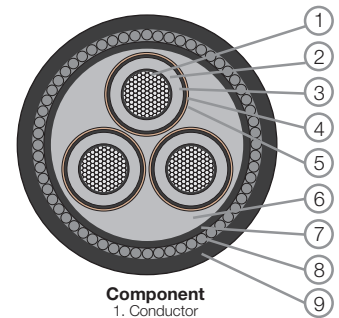
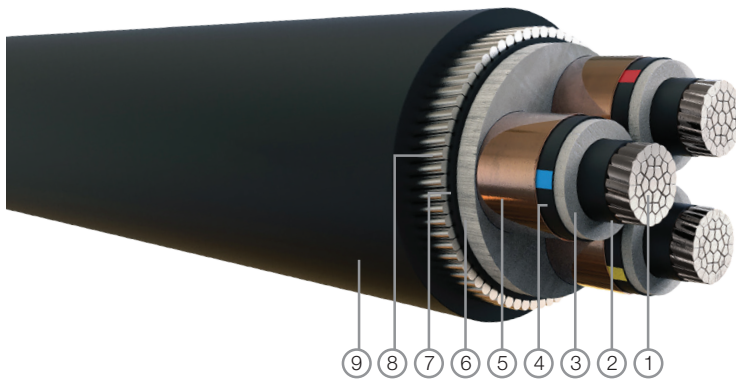

- Component**
1. Conductor
 2. Conductor screen
 3. Insulation
 4. Insulation screen
 5. Metallic screen (copper wire or copper tape)
 6. Filler & Binder Tape
 7. Inner sheath
 8. Armour
 9. Outer sheath

CONSTRUCTION

Conductor:	Plain Annealed Aluminium, Class 2 Conductor
Conductor Screen:	Extruded Semi Conductive Compound
Insulation:	Cross-linked Polyethylene (XLPE) Compound
Insulation Screen:	Extruded Semi Conductive Compound
Metallic Screen:	Copper Tape Screen
Assembled Core:	PP Yarn Filler with Binder Tape
Inner Sheath:	LSZH Flame Retardant Polyolefin
Armour:	Steel Wire Armour (SWA)
Outer Sheath:	LSZH Flame Retardant Polyolefin
Outer Sheath Colour:	Black (other colours upon request)

ELECTRICAL CHARACTERISTICS

Operating Voltage:	8.7/15KV
Conductor Operating Temperature:	90°C
Final Short Circuit Temperature:	250°C
Test Voltage:	3.5U ₀

AL/XLPE/CTS/LSZH/SWA/LSZH (Three Core)

Nominal Area of Conductor (mm ²)	Nominal Diameter of Conductor (mm)	Approximate Weight of Conductor (kg/km)	Nominal Thickness of Insulation (mm)	Nominal Thickness of Inner Sheath (mm)	Nominal Armour Wire Diameter (mm)	Nominal Thickness of Outer Sheath (mm)	Approximate Overall Diameter (mm)	Approximate Cable Weight (kg/km)
50	8.2	383	4.5	1.5	2.5	2.8	62	5,800
70	9.7	557	4.5	1.5	2.5	2.9	66	6,400
95	11.3	768	4.5	1.6	2.5	3.0	70	7,300
120	12.8	970	4.5	1.7	2.5	3.1	73	8,000
150	14.2	1,193	4.5	1.7	2.5	3.2	77	8,700
185	15.9	1,509	4.5	1.8	3.15	3.4	82	10,500
240	18.3	1,974	4.5	1.9	3.15	3.6	88	11,900
300	20.3	2,457	4.5	2.0	3.15	3.7	93	14,200
400	23.2	3,142	4.5	2.1	3.15	4.0	99	16,000

Table 58

FRT-AL-XCTSH AL/XLPE/CTS/LSZH/SWA/LSZH (Three Core)

XLPE Insulated, LSZH Bedded, Steel Wire Armoured, LSZH Sheathed Cable
12.7/22KV (Max 24), IEC 60502-2

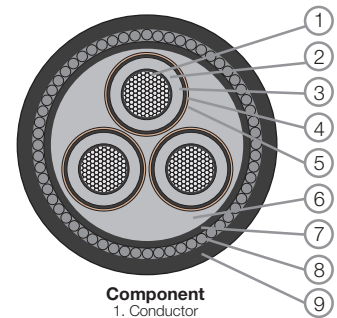
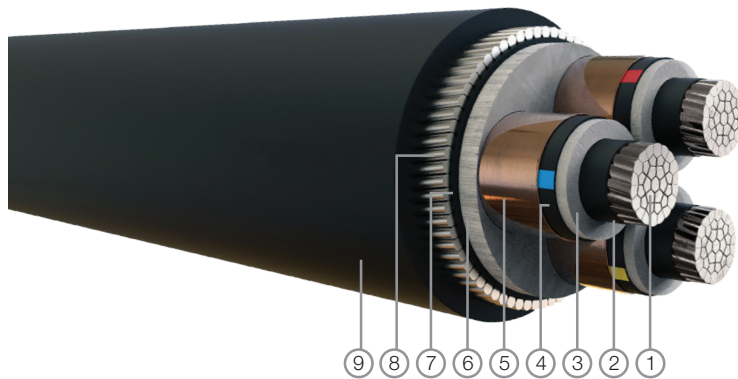

Component

1. Conductor
2. Conductor screen
3. Insulation
4. Insulation screen
5. Metallic screen (copper wire or copper tape)
6. Filler & Binder Tape
7. Inner sheath
8. Armour
9. Outer sheath

CONSTRUCTION

Conductor:	Plain Annealed Aluminium, Class 2 Conductor
Conductor Screen:	Extruded Semi Conductive Compound
Insulation:	Cross-linked Polyethylene (XLPE) Compound
Insulation Screen:	Extruded Semi Conductive Compound
Metallic Screen:	Copper Tape Screen
Assembled Core:	PP Yarn Filler with Binder Tape
Inner Sheath:	LSZH Flame Retardant Polyolefin
Armour:	Steel Wire Armour (SWA)
Outer Sheath:	LSZH Flame Retardant Polyolefin
Outer Sheath Colour:	Black (other colours upon request)

ELECTRICAL CHARACTERISTICS

Operating Voltage:	12.7/22KV
Conductor Operating Temperature:	90°C
Final Short Circuit Temperature:	250°C
Test Voltage:	3.5U ₀

AL/XLPE/CTS/LSZH/SWA/LSZH (Three Core)

Nominal Area of Conductor (mm ²)	Nominal Diameter of Conductor (mm)	Approximate Weight of Conductor (kg/km)	Nominal Thickness of Insulation (mm)	Nominal Thickness of Inner Sheath (mm)	Nominal Armour Wire Diameter (mm)	Nominal Thickness of Outer Sheath (mm)	Approximate Overall Diameter (mm)	Approximate Cable Weight (kg/km)
50	8.2	383	5.5	1.6	2.5	2.9	67	6,200
70	9.7	557	5.5	1.6	2.5	3.1	71	6,700
95	11.3	768	5.5	1.7	2.5	3.2	75	7,700
120	12.8	970	5.5	1.7	3.15	3.3	79	9,300
150	14.2	1,193	5.5	1.8	3.15	3.4	83	10,100
185	15.9	1,509	5.5	1.9	3.15	3.6	87	11,100
240	18.3	1,974	5.5	2.0	3.15	3.7	93	12,500
300	20.3	2,457	5.5	2.0	3.15	3.9	97	14,700
400	23.2	3,142	5.5	2.2	3.15	4.1	105	16,600

Table 59

FRT-AL-XCTSH AL/XLPE/CTS/LSZH/SWA/LSZH (Three Core)

XLPE Insulated, LSZH Bedded, Steel Wire Armoured, LSZH Sheathed Cable
19/33KV (Max 36), IEC 60502-2

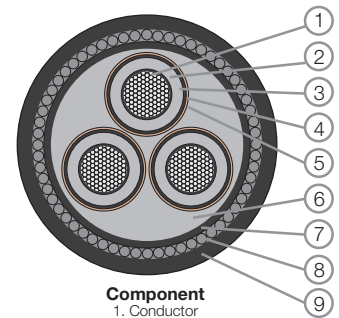
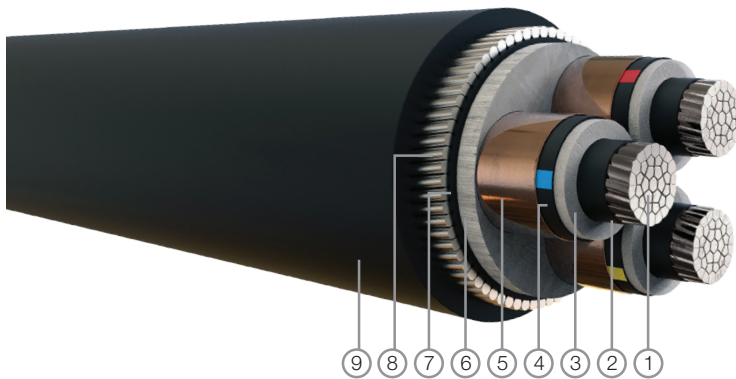

- Component**
1. Conductor
 2. Conductor screen
 3. Insulation
 4. Insulation screen
 5. Metallic screen (copper wire or copper tape)
 6. Filler & Binder Tape
 7. Inner sheath
 8. Armour
 9. Outer sheath

CONSTRUCTION

Conductor:	Plain Annealed Aluminium, Class 2 Conductor
Conductor Screen:	Extruded Semi Conductive Compound
Insulation:	Cross-linked Polyethylene (XLPE) Compound
Insulation Screen:	Extruded Semi Conductive Compound
Metallic Screen:	Copper Tape Screen
Assembled Core:	PP Yarn Filler with Binder Tape
Inner Sheath:	LSZH Flame Retardant Polyolefin
Armour:	Steel Wire Armour (SWA)
Outer Sheath:	LSZH Flame Retardant Polyolefin
Outer Sheath Colour:	Black (other colours upon request)

ELECTRICAL CHARACTERISTICS

Operating Voltage:	19/33KV
Conductor Operating Temperature:	90°C
Final Short Circuit Temperature:	250°C
Test Voltage:	3.5U ₀

AL/XLPE/CTS/LSZH/SWA/LSZH (Three Core)

Nominal Area of Conductor (mm ²)	Nominal Diameter of Conductor (mm)	Approximate Weight of Conductor (kg/km)	Nominal Thickness of Insulation (mm)	Nominal Thickness of Inner Sheath (mm)	Nominal Armour Wire Diameter (mm)	Nominal Thickness of Outer Sheath (mm)	Approximate Overall Diameter (mm)	Approximate Cable Weight (kg/km)
50	8.2	383	8.0	1.8	3.15	3.4	80	9,000
70	9.7	557	8.0	1.8	3.15	3.5	84	9,400
95	11.3	768	8.0	1.9	3.15	3.6	88	9,700
120	12.8	970	8.0	2.0	3.15	3.7	92	11,600
150	14.2	1,193	8.0	2.0	3.15	3.8	95	12,100
185	15.9	1,509	8.0	2.1	3.15	4.0	99	13,500
240	18.3	1,974	8.0	2.2	3.15	4.1	105	14,400
300	20.3	2,457	8.0	2.3	3.15	4.3	110	17,200
400	23.2	3,142	8.0	2.4	3.15	4.5	116	18,600

Table 60

XCSP (Pilot Cable) Cu/XLPE/PVC/CTS/HDPE/SWA/PVC

XLPE Insulated, PVC Bedded, Copper Tape Collective Screen, PE Inner Sheathed, Steel Wire Armoured, Flame Retardant PVC Sheathed, 5kV Induced Voltage

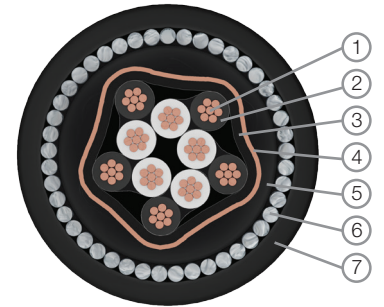

- Component**
1. Conductor
 2. Insulation
 3. Bedding
 4. Copper Tape Screen
 5. Separation Sheath
 6. Galvanised Steel Wire Armoured
 7. Outer Sheath

CONSTRUCTION

Conductor:	Plain Annealed Copper, Class 2 Conductor
Insulation:	Cross-linked Polyethylene (XLPE) Compound
Insulation Colour:	Black / White with Black Numberings
Cabling:	Cores twisted to form a pair with Individual Binder Tape
Assembly:	Requisite number of pairs are assembled together in concentric layers
Bedding:	Polyvinyl Chloride (PVC) Type ST2 Tape (LSZH upon request)
Metallic Screen:	Copper Tape Screen
Separation Sheath:	High Density Polyethylene (HDPE) Compound
Separation Sheath Colour:	Black
Armour:	Galvanised Steel Wire Armoured (SWA) (DSTA upon request)
Outer Sheath:	Flame Retardant Polyvinyl Chloride (PVC) Compound Type ST2 (LSZH upon request)
Outer Sheath Colour:	Black (other colours upon request)

ELECTRICAL CHARACTERISTICS

D.C. Conductor Resistance at 20°C:		
1.5mm ²	Max Ω/km	12.3
2.5mm ²	Max Ω/km	7.6
4mm ²	Max Ω/km	4.8
D.C. Insulation Resistance: Min MΩ.km 1000		
Maximum capacitance unbalanced pair to pair: pF/500m 500		
Voltage withstand test for 1 min: kV AC 5 (Between each conductor and the remaining conductors connected to the screen and armour)		

REFERENCE STANDARDS

BS 7870; IEC 60502-1; IEC 60228; IEC 60332-1; IEC 60332-3-24

Cu/XLPE/CTS/HDPE/SWA/PVC

No. of Pairs	Nominal Area of Conductor (mm ²)	No./ Wire Diameter (no./mm)	Nominal Insulation Thickness (mm)	Nominal Copper Tape Thickness (mm)	Nominal Inner Sheath Thickness (mm)	Approx Diameter Under Armour (mm)	Nominal Armour Wire Diameter (mm)	Nominal Outer Sheath Thickness (mm)	Approx Overall Diameter (mm)	Approx Cable Weight (kg/km)
5	1.5	7 / 0.53	0.8	0.1	1.4	20.8	1.6	1.7	27	1360
10	1.5	7 / 0.53	0.8	0.1	1.5	28.6	1.6	2.0	36	2070
15	1.5	7 / 0.53	0.8	0.1	1.6	31.7	1.6	2.1	39	2440
20	1.5	7 / 0.53	0.8	0.1	1.6	35.0	2.0	2.3	44	3100
5	2.5	7 / 0.67	0.8	0.1	1.4	22.7	1.6	1.8	30	1580
10	2.5	7 / 0.67	0.8	0.1	1.5	31.5	1.6	2.1	39	2440
15	2.5	7 / 0.67	0.8	0.1	1.6	35.0	2.0	2.3	44	3080
20	2.5	7 / 0.67	0.8	0.1	1.7	39.0	2.0	2.4	48	3720
5	4	7 / 0.85	1.0	0.1	1.5	28.8	1.6	1.9	36	2160
10	4	7 / 0.85	1.0	0.1	1.6	36.6	2.0	2.2	45	2800
15	4	7 / 0.85	1.0	0.1	1.7	40.2	2.0	2.4	49	3440
20	4	7 / 0.85	1.0	0.1	1.8	44.0	2.0	2.5	54	4230

Table 61

CABLE TECHNICAL DATA

Max. conductor DC resistance at 20°C							
Nominal Cross Section (mm ²)	50	70	95	120	150	185	240
Cu	0.387	0.268	0.193	0.153	0.124	0.0991	0.0754
Al	0.641	0.443	0.320	0.253	0.206	0.164	0.125
Nominal Cross Section (mm ²)	300	400	500	630	800	1000	1200
Cu	0.0601	0.0470	0.0366	0.0283	0.022	0.0176	0.0151
Al	0.100	0.0778	0.0605	0.0469	0.0367	0.0291	0.0247

Table 62

Frequency voltage test, partial discharge test and impulse voltage test						
Rated voltage (kV)		3.8/6.6	6.35/11	8.7/15	12.7/22	19/33
Frequency Voltage Test	Test voltage (kV)	13.3	22.2	30.5	44.5	66.5
	Duration (min)	5	5	5	5	5
Partial Discharge Test	Test voltage (kV)	6.6	11.0	15.1	22.0	32.9
	Max. partial discharge sensitivity, pC	10	10	10	10	10
Impulse Voltage Test	Test voltage (kV)	60	75	95	125	170

Table 63

Max. conductor short-circuit current at 250°C(kA / 1s)							
Conductor Cross Section (mm ²)	50	70	95	120	150	185	240
Cu	7.2	10.0	13.6	17.2	21.5	26.5	34.3
Al	4.7	6.6	8.9	11.3	14.1	17.4	22.6
Conductor Cross Section (mm ²)	300	400	500	630	800	1000	1200
Cu	42.9	57.2	71.5	90.1	114.4	143.0	171.6
Al	28.2	37.6	47.0	59.2	75.2	94.0	112.8

Table 64

Cable capacitance (µF/km)						
Conductor Cross Section (mm ²)	Rated Voltage (kV)	3.8/6.6	6.35/11	8.7/15	12.7/22	19/33
50		0.33	0.26	0.21	0.18	0.14
70		0.38	0.29	0.24	0.20	0.16
95		0.42	0.33	0.26	0.22	0.18
120		0.46	0.36	0.28	0.24	0.19
150		0.51	0.39	0.31	0.26	0.20
185		0.55	0.42	0.33	0.28	0.22
240		0.61	0.47	0.37	0.31	0.24
300		0.65	0.51	0.40	0.34	0.26
400		0.69	0.59	0.46	0.39	0.28
500		0.76	0.65	0.52	0.44	0.32
630		0.83	0.72	0.56	0.47	0.35

Table 65

XLPE INSULATED PVC OR LSZH SHEATHED CABLE CURRENT CARRYING CAPACITY

Current carrying capacity calculation conditions

- Conductor operating temperature: 90°C
- Ambient air temperature: 40°C
- Ground temperature: 25°C
- Underground laying, the soil thermal resistivity is 1.5 K-m/W and earthenware thermal resistivity is 1.2 K-m/W

Current carrying capacity correction factor

Correction factors for ambient temperature ground installation.

(1) Ambient temperature correction factor								
Conductor Temperature	Ambient temperature (in air)							
	20	25	30	35	40	45	50	55
90	1.23	1.17	1.12	1.06	1.00	0.94	0.87	0.81
Conductor Temperature	Ambient temperature (in ground)							
	10	15	20	25	30	35	-	-
90	1.11	1.07	1.04	1.00	0.96	0.92	-	-

Table 66

(2) Correction factors for depths of laying other than 0.8 m for direct buried cables			
Depth of Laying (m)	Single-core cables		Three-core cables
	Nominal Conductor Size (mm ²)		
	≤185 mm ²	>185 mm ²	
0.5	1.04	1.06	1.04
0.6	1.02	1.04	1.03
1	0.98	0.97	0.98
1.25	0.96	0.95	0.96
1.5	0.95	0.93	0.95
1.75	0.94	0.91	0.94
2	0.93	0.90	0.93
2.5	0.91	0.88	0.91
3	0.90	0.86	0.90

Table 67

(3) Correction factors for depths of laying other than 0.8 m for cables in ducts			
Depth of Laying (m)	Single-core cables		Three-core cables
	Nominal Conductor Size (mm ²)		
	≤185 mm ²	>185 mm ²	
0.5	1.04	1.05	1.03
0.6	1.02	1.03	1.02
1	0.98	0.97	0.99
1.25	0.96	0.95	0.97
1.5	0.95	0.93	0.96
1.75	0.94	0.92	0.95
2	0.93	0.91	0.94
2.5	0.91	0.89	0.93
3	0.90	0.88	0.92

Table 68

(4) Correction factors for soil thermal resistivities other than 1.5 K-m/W for direct buried single-core cables							
Nominal Area of Conductor (mm²)	Values of soil thermal resistivity (K-m/W)						
	0.7	0.8	0.9	1	2	2.5	3
70	1.33	1.27	1.22	1.17	0.89	0.81	0.74
95	1.34	1.28	1.22	1.18	0.89	0.80	0.74
120	1.34	1.28	1.22	1.18	0.88	0.80	0.74
150	1.35	1.28	1.23	1.18	0.88	0.80	0.74
185	1.35	1.29	1.23	1.18	0.88	0.80	0.74
240	1.36	1.29	1.23	1.18	0.88	0.80	0.73
300	1.36	1.30	1.24	1.19	0.88	0.80	0.73
400	1.37	1.30	1.24	1.19	0.88	0.79	0.73

Table 69

(5) Correction factors for soil thermal resistivities other than 1.5 K-m/W for single-core cables in buried ducts							
Nominal Area of Conductor (mm²)	Values of soil thermal resistivity (K-m/W)						
	0.7	0.8	0.9	1	2	2.5	3
70	1.22	1.19	1.15	1.12	0.91	0.84	0.78
95	1.23	1.19	1.16	1.13	0.91	0.84	0.78
120	1.23	1.20	1.16	1.13	0.91	0.84	0.78
150	1.24	1.20	1.16	1.13	0.91	0.83	0.78
185	1.24	1.20	1.17	1.13	0.91	0.83	0.78
240	1.25	1.21	1.17	1.14	0.90	0.83	0.77
300	1.25	1.21	1.17	1.14	0.90	0.83	0.77
400	1.25	1.21	1.17	1.14	0.90	0.83	0.77

Table 70

(6) Correction factors for soil thermal resistivities other than 1.5 K-m/W for direct buried three-core cables							
Nominal Area of Conductor (mm²)	Values of soil thermal resistivity (K-m/W)						
	0.7	0.8	0.9	1	2	2.5	3
50	1.25	1.21	1.17	1.14	0.91	0.83	0.77
70	1.26	1.21	1.18	1.14	0.90	0.83	0.77
95	1.26	1.22	1.18	1.14	0.90	0.83	0.77
120	1.26	1.22	1.18	1.14	0.90	0.83	0.77
150	1.27	1.22	1.18	1.15	0.90	0.83	0.77
185	1.27	1.23	1.18	1.15	0.90	0.83	0.77
240	1.28	1.23	1.19	1.15	0.90	0.83	0.77
300	1.28	1.23	1.19	1.15	0.90	0.82	0.77
400	1.28	1.23	1.19	1.15	0.90	0.82	0.76

Table 71

(7) Correction factors for soil thermal resistivities other than 1.5 K-m/W for three-core cables in ducts							
Nominal Area of Conductor (mm²)	Values of soil thermal resistivity (K-m/W)						
	0.7	0.8	0.9	1	2	2.5	3
50	1.14	1.13	1.10	1.08	0.94	0.88	0.84
70	1.15	1.13	1.11	1.09	0.94	0.88	0.83
95	1.15	1.13	1.11	1.09	0.94	0.88	0.83
120	1.15	1.13	1.11	1.09	0.93	0.88	0.83
150	1.16	1.13	1.11	1.09	0.93	0.88	0.83
185	1.16	1.14	1.11	1.09	0.93	0.87	0.83
240	1.16	1.14	1.12	1.10	0.93	0.87	0.82
300	1.17	1.14	1.12	1.10	0.93	0.87	0.82
400	1.17	1.14	1.12	1.10	0.92	0.86	0.81

Table 72

(8) Correction factors for groups of three-core cables in horizontal formation laid direct in ground						
Number of cables in group	Spacing between cable centres (mm)					
	Touching	200	400	600	800	
2	0.80	0.86	0.92	0.92	0.94	
3	0.69	0.77	0.82	0.86	0.89	
4	0.62	0.72	0.79	0.83	0.87	
5	0.57	0.68	0.76	0.81	0.85	
6	0.54	0.65	0.74	0.80	0.84	
7	0.51	0.63	0.72	0.78	0.83	
8	0.49	0.61	0.71	0.78	-	
9	0.47	0.60	0.70	0.77	-	
10	0.46	0.59	0.69	-	-	
11	0.45	0.57	0.69	-	-	
12	0.43	0.56	0.68	-	-	

Table 73

(9) Correction factors for groups of three-phase circuits of single-core cables laid direct in ground						
Number of cables in group	Spacing between cable centres (mm)					
	Touching	200	400	600	800	
2	0.73	0.83	0.88	0.90	0.92	
3	0.60	0.73	0.79	0.83	0.86	
4	0.54	0.68	0.75	0.80	0.84	
5	0.49	0.63	0.72	0.78	0.82	
6	0.46	0.61	0.70	0.76	0.81	
7	0.43	0.58	0.68	0.75	0.80	
8	0.41	0.57	0.67	0.74	-	
9	0.39	0.55	0.66	0.73	-	
10	0.37	0.54	0.65	-	-	
11	0.36	0.53	0.64	-	-	
12	0.35	0.52	0.64	-	-	

Table 74

(10) Correction factors for groups of three-core cables in single way ducts in horizontal formation					
Number of cables in group	Spacing between cable centres (mm)				
	Touching	200	400	600	800
2	0.85	0.88	0.92	0.94	0.95
3	0.75	0.80	0.85	0.88	0.91
4	0.69	0.75	0.82	0.86	0.89
5	0.65	0.72	0.79	0.84	0.87
6	0.62	0.69	0.77	0.83	0.87
7	0.59	0.67	0.76	0.82	0.86
8	0.57	0.65	0.75	0.81	-
9	0.55	0.64	0.74	0.80	-
10	0.54	0.63	0.73	-	-
11	0.52	0.62	0.73	-	-
12	0.51	0.61	0.72	-	-

Table 75

(11) Correction factors for groups of three-phase circuits of single-core cables in single way ducts					
Number of cables in group	Spacing between cable centres (mm)				
	Touching	200	400	600	800
2	0.78	0.85	0.89	0.91	0.93
3	0.66	0.75	0.81	0.85	0.88
4	0.59	0.70	0.77	0.82	0.86
5	0.55	0.66	0.74	0.80	0.84
6	0.51	0.64	0.72	0.78	0.83
7	0.48	0.61	0.71	0.77	0.82
8	0.46	0.60	0.70	0.76	-
9	0.44	0.58	0.69	0.76	-
10	0.43	0.57	0.68	-	-
11	0.42	0.56	0.67	-	-
12	0.40	0.55	0.67	-	-

Table 76

**(12) Reduction factors for groups of more than one multi-core cable in air -
To be applied to the current-carrying capacity of one multi-core cable in free air**

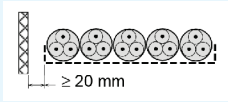
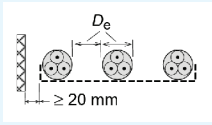
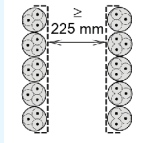
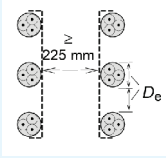
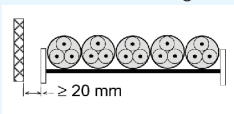
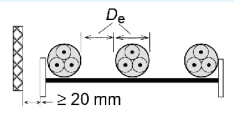
Method of installation		Number of trays	Number of cables					
			1	2	3	4	5	6
Cables on perforated trays	<p>Cables touching</p> 	1	1.00	0.88	0.82	0.79	0.76	0.73
		2	1.00	0.87	0.80	0.77	0.73	0.68
		3	1.00	0.86	0.79	0.76	0.71	0.66
	<p>Cables spaced</p> 	1	1.00	1.00	0.98	0.95	0.91	-
		2	1.00	0.99	0.96	0.92	0.87	-
		3	1.00	0.98	0.95	0.91	0.85	-
Cables on vertical perforated trays	<p>Cables touching</p> 	1	1.00	0.88	0.82	0.78	0.73	0.72
		2	1.00	0.88	0.81	0.76	0.71	0.70
	<p>Cables spaced</p> 	1	1.00	0.91	0.89	0.88	0.87	-
		2	1.00	0.91	0.88	0.87	0.85	-
		3	1.00	0.91	0.88	0.87	0.85	-
		4	1.00	0.91	0.88	0.87	0.85	-
Cables on ladder supports, cleats, etc.	<p>Cables touching</p> 	1	1.00	0.87	0.82	0.80	0.79	0.78
		2	1.00	0.86	0.80	0.78	0.76	0.73
		3	1.00	0.85	0.79	0.76	0.73	0.70
	<p>Cables spaced</p> 	1	1.00	1.00	1.00	1.00	1.00	-
		2	1.00	0.99	0.98	0.97	0.96	-
		3	1.00	0.98	0.97	0.96	0.93	-

- Note:**
1. Values given are averages for the cable types and range of conductor sizes considered. The spread of values is generally less than 5%.
 2. Factors apply to single layer groups of cables as shown above and do not apply when cables are installed in more than one layer touching each other. Values for such installations may be significantly lower and must be determined by an appropriate method.
 3. Values are given for vertical spacings between trays of 300 mm and at least 20 mm between trays and walls. For closer spacing, the factors should be reduced.
 4. Values are given for horizontal spacings between trays of 225 mm with trays mounted back to back. For closer spacing, the factors should be reduced.

Table 77

**(13) Reduction factors for groups of more than one circuit of single-core cables
(Note 2) To be applied to the current-carrying capacity of one circuit of single-core cables in free air**

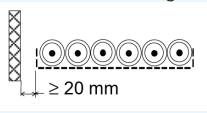
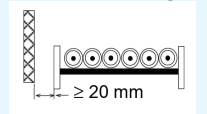
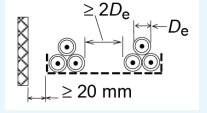
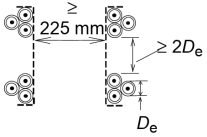
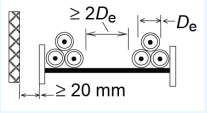
Method of installation	Number of trays	Number of three-phase circuits (Note 5)			Use as a multiplier to rating for		
		1	2	3			
Perforated trays (Note 3)	Cables touching 		1	0.98	0.91	0.87	Three cables in horizontal formation
			2	0.96	0.87	0.81	
			3	0.95	0.85	0.78	
Ladder supports, cleats etc. (Note 3)	Cables touching 		1	1.00	0.97	0.96	Three cables in horizontal formation
			2	0.98	0.93	0.89	
			3	0.97	0.90	0.86	
Perforated trays (Note 3)			1	1.00	0.98	0.96	Three cables in trefoil formation
			2	0.97	0.93	0.89	
			3	0.96	0.92	0.86	
Vertical perforated trays (Note 4)	Cables spaced 		1	1.00	0.91	0.89	Three cables in trefoil formation
			2	1.00	0.90	0.86	
Ladder supports, cleats etc. (Note 3)			1	1.00	1.00	1.00	Three cables in trefoil formation
			2	0.97	0.95	0.93	
			3	0.96	0.94	0.90	

- Note:**
- 1, Values given are averages for the cable types and range of conductor sizes considered. The spread of values is generally less than 5%.
 - 2, Factors are given for single layers of cables (or trefoil groups) as shown in the table and do not apply when cables are installed in more than one layer touching each other. Values for such installations may be significantly lower and should be determined by an appropriate method.
 - 3, Values are given for horizontal spacings between trays of 300 mm. For closer spacing, the factors should be reduced.
 - 4, Values are given for vertical spacings between trays of 225 mm with trays mounted back to back. For closer spacing, the factors should be reduced.
 - 5, For circuits having more than one cable in parallel per phase, each three phase set of conductors should be considered as a circuit for the purpose of this table.

Table 78

Current Carrying Capacity for Single-core XLPE insulated PVC or LSZH sheathed cables

3.8/6.6 kV ~ 19/33 kV Aluminium Conductor			
Nominal area of conductor	Buried direct in ground	In single-way ducts	In air
	Trefoil	Trefoil ducts	Trefoil
			
Cross Section (mm ²)	Current carrying capacity (A)		
70	178	168	209
95	212	201	254
120	241	230	294
150	269	256	334
185	304	290	385
240	352	336	456
300	397	381	525
400	451	432	612
500	500	490	690
630	570	550	800
800	640	625	930
1000	710	690	1050
1200	780	755	1170
Maximum conductor temperature: 90°C Depth of laying: 0.8m	Ambient air temperature: 40°C Thermal resistivity of soil: 1.5 K·m/W	Ground temperature: 25°C Thermal resistivity of earthenware ducts: 1.2K·m/W	

Table 79

Current Carrying Capacity for Three-core XLPE insulated PVC or LSZH sheathed cables

(A) 3.8/6.6 kV ~ 19/33 kV Aluminium Conductor, unarmoured			
Nominal area of conductor	Buried direct in ground	In single-way ducts	In air
	Trefoil	Trefoil ducts	Trefoil
			
Cross Section (mm ²)	Current carrying capacity (A)		
50	134	117	143
70	164	144	178
95	194	171	214
120	222	196	248
150	249	221	281
185	282	251	323
240	326	292	377
300	368	332	432
400	420	382	502
Maximum conductor temperature: 90°C Depth of laying: 0.8m		Ambient air temperature: 40°C Thermal resistivity of soil: 1.5 K·m/W	Ground temperature: 25°C Thermal resistivity of earthenware ducts: 1.2K·m/W

Table 80

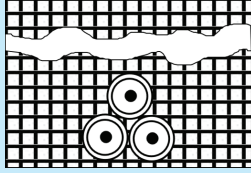
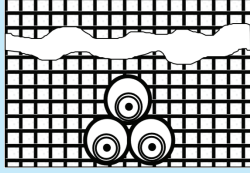
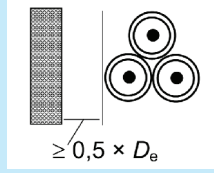
(B) 3.8/6.6 kV ~ 19/33 kV Aluminium Conductor, armoured			
Nominal area of conductor	Buried direct in ground	In single-way ducts	In air
	Trefoil	Trefoil ducts	Trefoil
			
Cross Section (mm ²)	Current carrying capacity (A)		
50	134	118	144
70	164	144	178
95	195	172	216
120	222	197	249
150	248	221	281
185	281	251	322
240	324	291	377
300	364	329	429
400	414	377	495
Maximum conductor temperature: 90°C Depth of laying: 0.8m		Ambient air temperature: 40°C Thermal resistivity of soil: 1.5 K·m/W	Ground temperature: 25°C Thermal resistivity of earthenware ducts: 1.2K·m/W

Table 81

TERMS & CONDITIONS OF SALES

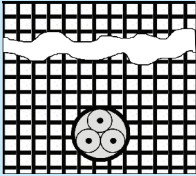
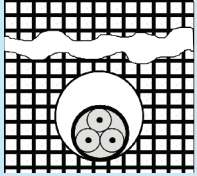
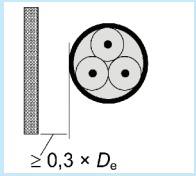
1. APPLICATION OF TERMS & CONDITIONS

These conditions govern the sale and purchase of goods ordered by Buyer from Seller ("the goods") and shall override any terms and conditions whether previously or hereafter stipulated incorporated or referred to by Buyer whether orally in its purchase order or other documents.

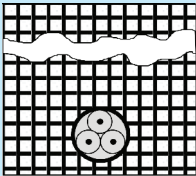
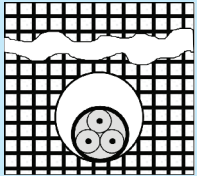
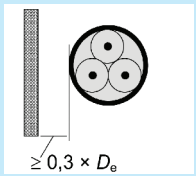
2. DELIVERY

- a. Any time for delivery named by Seller is an estimate only and Seller is not liable to make good any damage or loss arising out of any such delay.
- b. Delivery shall be deemed to have been made if Seller delivers the goods to the location specified by the Buyer and Delivery Order is endorsed by any person present thereat. Seller is not responsible to ensure the goods have been delivered to or is collected by Buyer or its authorised personnel and shall not be liable for any loss or damage to Buyer by reason of unauthorised collection of the goods.
- c. Should Buyer fail to take delivery of goods, Seller shall be entitled (without derogation of its rights under Law) to charge Buyer for storage and insurance for the goods calculated from the date fixed for delivery.
- d. The Seller reserves the right to deliver the goods by instalments and each instalment shall be deemed to have been sold under a separate contract. Failure to deliver any instalment shall not entitle the buyer to repudiate the contract.
- e. Off loading and/or handling will in all events be the responsibility of the Buyer.
- f. If the goods to be delivered are, at the Buyer's discretion, delivered to the destination other than the Buyer's premises, the Seller will arrange such delivery for the Buyer and all costs for carriage and insurance will be borne by the Buyer.
- g. Availability of the goods when offered ex-stock is subject to such goods being sold in another transaction between the date when the Seller advises the goods are available, and the date when it receives the Buyer's order. Any delivery time offered for products made to special customer order is indicative only, and the Seller shall not be liable for any loss or damage whatsoever arising as a consequence or result of any such failure to deliver.

3. PRICE

The quoted prices for the goods are subject to change in the event of any imposition or increase in taxes, levies or duties whatsoever on the goods, its components or raw materials.

4. PAYMENT

Payment for the goods shall be made within the time stipulated in the invoice. Interest at 1.5% per month will be charged on late payment.

5. TIME OF THE ESSENCE

Time within which the Buyer is to buy for the goods shall be of the essence of this Contract.

6. ACCEPTANCE

Buyer shall inspect the goods immediately upon delivery. Unless Seller receives notice that the goods are not in accordance with the Buyer's order and the goods returned to Seller within 24 hours from the date of delivery, the goods shall be deemed to have been accepted by the Buyer PROVIDED ALWAYS Seller will not accept return of used goods and Buyer shall not reject any goods which are in accordance with the Buyer's order.

7. DESCRIPTION

Notwithstanding any description of the goods given by the Seller or Buyer, no sale of goods shall constitute or be construed as a sale by description.

8. WARRANTIES

Save and except for written warranties (if any) given by Seller, the Seller does not give any warranties as to the quality, state, condition or fitness of the goods or their suitability for any purpose or for use under any specific conditions, notwithstanding that such purpose or condition may be known or make known to Seller.

9. DEFECTS

Save and except as notified pursuant to Clause (6) above, Seller shall be under no liability to Buyer either in contract or tort for loss, injury or damage sustained by Buyer or any third party by reason of defects in the goods whether latent or otherwise but Buyer will keep Seller indemnified against any such claim.

10. TITLE

Title to the goods remains vested in Seller until Seller receives payment for the full purchase price. If such payment is overdue, the Seller may without prejudice to any other rights sue for the purchase price, recover or re-sell the goods and the Buyer grants the Seller, its servants/agents the right and/or licence to enter the Buyer's premise and/or any other premise where the goods are stored. If any of the goods are sold by Buyer before title has passed to Buyer, Buyer shall hold the proceeds of sale and all rights against purchaser in trust for Seller.

11. RISK

Risk passes to Buyer upon delivery of goods to Buyer.

12. DEFAULT

If Buyer fail to pay Seller on due date, commits a breach of any of its obligation herein, becomes insolvent or commits an act of bankruptcy, Seller may without prejudice to its other rights and without giving any notice, suspend/cancel further deliveries, stop any delivery in transit under this Contract or any other contracts and/or limit/cancel the Buyer's credit as to time and/or amount for executed, executory or future orders, and/or request for securities or guarantees. Seller shall not be liable to Buyer for any damages which Buyer may suffer or incur by reason thereof.

13. CANCELLATION OF CREDIT

Notwithstanding anything herein contained, Seller reserves the right to limit/cancel the credit of the Buyer as to time and/or amount without giving any reasons thereof and to demand full settlement immediately of all sums that may be owing by Buyer notwithstanding that the credit period has not expired.

14. FORCE MAJEURE

Seller shall not be liable to Buyer for failure to deliver the goods by reason of any breakdown of plant, fire, explosion, Act of God, or outbreak of hostilities, national emergency, industrial disputes, shortage of labour, raw materials, energy or any causes beyond Seller's control and which Seller is unable to prevent by the exercise of reasonable diligence, whether of the class of causes enumerated herein or not.

15. APPROPRIATION OF PAYMENTS

All payments received from the Buyer will be applied towards settlement of the Buyer's oldest debts comprising of the earliest invoices, debit notes (including debit notes for overdue interest) and other charges howsoever arising PROVIDED ALWAYS Seller may appropriate any payments towards account of interest before principal in respect of any debt as the Seller shall in its absolute discretion deem fit.

16. STATEMENT OF ACCOUNT

All amounts stated in the invoices and statement of accounts of Seller shall be conclusive of the amounts due and owing by Buyer to Seller and shall be binding against Buyer in any legal proceedings.

17. RIGHTS OF SET-OFF

Seller entitled to set-off against Buyer's debts all monies now or hereafter standing to the credit of Buyer's account with Seller and for this purpose Buyer shall give irrevocable authority to Seller to collect on behalf of Buyer and give valid receipt and discharge in respect of all such monies owing to the Buyer.

18. WAIVER

No failure or delay by the Seller in exercising any rights hereunder shall operate as a waiver hereof nor shall any single or partial exercise of right preclude any further exercise thereof or the exercises of any other right.

19. SALE OF GOODS ACT ("the Act")

The terms and conditions in favour of the Seller hereunder shall be in addition to and not in substitution for any term condition warranty expressed or implied in favour of the Seller under the Act or any statutory and re-enactment thereto for the time being enforced.

20. INFRINGEMENT OF PATENTS DESIGNS

Buyer shall indemnify Seller against all damages, claims, costs and expenses which Seller may become liable as a result of work done or goods sold in accordance with Buyer's specifications which involves infringement of any patents, registered designs or trademarks.

21. NOTICES

Any notices, communications or demands shall be deemed to have been sufficiently given if sent by prepaid post to the address of the addressee stated herein or to the addressee's last known place of business and shall be presumed to have reached the address in ordinary course of post.

General Disclaimer We have taken reasonable measures to ensure that the information and data represented in this catalogue is accurate and current. However, Tai Sin makes no express or implied warranty regarding such information or data, and hereby expressly disclaims all responsibility and legal liability to persons or entities that use or access its content, based on their reliance on any information or data that is available through this catalogue. We are not liable for all expenses, losses, damages and costs you might incur as a result of the information being inaccurate or incomplete in any way, and for any reason. JLY Group Co Ltd is a leading innovator, marketer and cable manufacturer in China. JLY-Tai Sin brand cables are produced under the collaboration of JLY Group Co Ltd and Tai Sin Electric Limited.



Factories and Regional Offices

Tai Sin Electric Limited

24 Gul Crescent
Singapore 629531
Tel: (+65) 6672 9292
Fax: (+65) 6861 4084
E-Mail: sales@taisin.com.sg
Website: www.taisin.com.sg

**Tai Sin Electric Cables
(Malaysia) Sdn. Bhd.**

PTD 37433, 37434 & 37444
Off Jalan Perindustrian Senai 3
Kawasan Perindustrian Senai Fasa 3
81400 Senai
Johor Darul Takzim, Malaysia
Tel: (+60) 7 599 8888
Fax: (+60) 7 599 8898
E-Mail: sales@taisin.com.my
Website: www.taisin.com.my

**Tai Sin Electric Cables
(VN) Co., Ltd.**

No.20, VSIP II Street 2
Vietnam - Singapore Industrial Park 2
Hoa Phu Ward, Thu Dau Mot City
Binh Duong Province, Vietnam
Tel: (+84) 650 3635 088
Fax: (+84) 650 3635 077
E-Mail: sales@taisin.com.vn
Website: www.taisin.com.vn